

16-8955
April 21, 1986

Williams[®] 

**Pinball Troubleshooting &
Reference Manual**



by James T. Hawes

Illustrated by Sebastian J. Ortega

ROM Summary For A Typical System-9 Game

| IC | DESCRIPTION | TYPE | NUMBER | BOARD |
|------------|----------------|-------|--------|-------|
| Game ROM 1 | ROM 8Kx8 bits | 2764 | U20 | CPU |
| Game ROM 2 | ROM 4Kx8 bits | 2732 | U19 | CPU |
| Sound ROM | ROM 16Kx8 bits | 27128 | U49 | CPU |
| Speech ROM | ROM 4Kx8 bits | 2732* | U4 | CPU |
| Speech ROM | ROM 4Kx8 bits | 2732* | U5 | CPU |
| Speech ROM | ROM 4Kx8 bits | 2732* | U6 | CPU |
| Speech ROM | ROM 4Kx8 bits | 2732* | U7 | CPU |

*Type 2532 ROMs may also be used for the speech ROMs.

NOTICE

TO ORDER REPLACEMENT ROMS from your authorized WILLIAMS ELECTRONICS GAMES distributor, specify (1) part number (if available), (2) ROM label color, (3) REV level (revision number) on the label, and (4) which game the ROM is used on.

Connector Code

WILLIAMS USES A SPECIAL TECHNIQUE to name jacks and plugs. Each connector receives a number, a letter, and a number. A hyphen separates the jack or plug designation from the pin number.

J-designations refer to the male part of a connector.

P-designations refer to the female part of a connector.

1J1 is board 1, jack 1 (a CPU Board jack).

3P6 is board 3, plug 6 (a Power-Supply plug).

For example, 1J1-3 refers to a connector at board 1, specifies the jack (male or board) side of the connector, identifies the connector as number one on the board, and stipulates pin number three.

The prefix numbers for System-9 games are as listed below:

| | |
|------------------------|-------------------------|
| 1-CPU Board | 9-Insert Board |
| 2-(not assigned) | 10-(not assigned) |
| 3-Power-Supply Board | 11-(not assigned) |
| 4-Master-Display Board | 12-Speech Board |
| 5-Slave-Display Board | 13-(not assigned) |
| 6-Backbox | 14-(not assigned) |
| 7-Cabinet | 15-Flipper Power Supply |
| 8-Playfield | 16-(not assigned) |

16-8955

April 21, 1986



Pinball Troubleshooting &
Reference Manual

by James T. Hawes
Illustrated by Sebastian J. Ortega

including...

- * Mechanical Servicing
- * Using The Publications
- * Electronic and Electromechanical Troubleshooting
- * Latest Reference Data

NOTICE

ALLEY CATS, COMET, HIGH SPEED, LANE CHANGE, MULTI-BALL, SORCERER, SPACE SHUTTLE, STAR LIGHT, STRIKE ZONE, and WILLIAMS ELECTRONICS GAMES, INC., reg. U.S. Pat. and TM. Office. USER FRIENDLY PINBALL is a trademark of WILLIAMS ELECTRONICS, INC.

Copyright © 1986 WILLIAMS ELECTRONICS GAMES, INC.
3401 N. California Ave.
Chicago, IL 60618
(312) 267-2240

-4-
Contents

| | |
|---|----|
| <u>CHAPTER 1. Mechanical Servicing</u> | 7 |
| Setup Procedures..... | 8 |
| Five-Minute Checkup..... | 9 |
| Weekly Service Program..... | 10 |
| Periodic, Major Procedures..... | 11 |
| Other Mechanical Adjustments..... | 12 |
| <u>CHAPTER 2. Using The Publications</u> | 15 |
| Game-Registration Card..... | 16 |
| Bookkeeping and Game-Adjustment Tables..... | 16 |
| Lamp-Matrix Table..... | 16 |
| Switch-Matrix Table..... | 18 |
| Solenoid Table..... | 18 |
| <u>CHAPTER 3. Electronic and Electromechanical Troubleshooting</u> | 19 |
| A Word On System Architecture..... | 20 |
| Pinouts for 6802 and 6808 Microprocessors..... | 22 |
| System 9 and the 6802/6808 Microprocessor..... | 25 |
| Electronic Service Procedures..... | 27 |
| Diagnosing Common Symptoms..... | 28 |
| Linear Power Supplies..... | 30 |
| Flippers..... | 31 |
| Switch Problems..... | 32 |
| Playfield Coils..... | 35 |
| Lamps..... | 39 |
| Displays..... | 42 |
| Sounds..... | 47 |
| Power, Bus and Clock Problems..... | 48 |
| Speech Board..... | 51 |
| <u>CHAPTER 4. Reference Information</u> | 53 |
| ROM Summary for a Typical System-9 Game..... | 2 |
| Connector Code..... | 2 |
| Preface..... | 5 |
| System-9 Games (in Chronological Order)..... | 6 |
| Function Finder: A glossary of electronic terms used by pinball technicians..... | 54 |
| Pin Functions of 6802 and 6808 Microprocessors..... | 68 |
| System-9 Control Locations..... | 69 |
| Replacing System-9 Circuitboards..... | 69 |
| All About Coil Numbers..... | 69 |
| An Introduction to Self-Diagnostics..... | 70 |
| System-9 Games Play on System 11..... | 71 |
| CPU-Board Jumper Table..... | 71 |
| Speech-ROM Comparison Table..... | 71 |
| System 9 to System 11 Conversion Table For Chapter 3..... | 72 |
| Index to the First Three Chapters..... | 75 |

Preface

WHO WILL USE THIS BOOK. This book is written for anyone who operates, services or owns an electronic pinball game. Because I want to convey a deductive reasoning process (as well as a system of techniques), many types of people should find this book useful.

THE MANUAL PROCESS. This book doesn't obsolete your game's service manual. The two are designed to work in concert. At WILLIAMS, constant technical innovations are the norm. They both made this book necessary and prevented this book from obsoleting other literature. This process doesn't end with The WILLIAMS Pinball Troubleshooting & Reference Manual or any other text. Because WILLIAMS is dedicated to supporting its games and following through with its customers, you have a place in the process. Please fill out the feedback form at the end of this book. What you write will have an effect. It may very well influence the production of another publication like this one. Or it may cause us to publish an entirely different type of document.

HOW TO USE THIS BOOK. The book is designed so that you can locate as much (or as little) information as you choose. For example if you can't relate to schematics, then a block diagram can be used to reduce a broken system to a broken section. If your interest is better switch performance, then consult the section on mechanical servicing. If you want to understand the language of WILLIAMS' instruction manuals, read the short chapter on using the manuals or find computer jargon defined in the glossary.

SYSTEMS. Because of modern games' complexity, I've had to go into detail on numerous topics. Your instruction manuals and schematics cover other areas. While there is some duplication between the material they cover and the material I cover here, most of this book is new. WILLIAMS has produced various pinball systems (computers) since electronic pins first appeared in 1977. Systems 4, 6, 7 and 8 precede this book's story. I concentrate on System 9 here. Meanwhile the engineers have produced two new marvels, System 10 and System 11. Fortunately the situation isn't as complicated as all these numbers. All these systems have numerous circuits in common. Electronic troubleshooting is virtually the same for the common circuits. And mechanical servicing is the same for most pinball games. Regardless of system and in many cases regardless of brand, this is true.

POINT OF REFERENCE. However this book needed a point of reference, and I decided on System 9. This decision prevented unnecessary complexity in the electronic troubleshooting charts. If you have a non-system-9 WILLIAMS game (usually a game made before mid-1984 or after 1985) I invite you to compare your game's schematics to those of a system-9 game. You'll have to take note of different part-numbering schemes and a few circuit distinctions. Despite these differences, troubleshooting for all WILLIAMS pinball, shuffle and novelty games proceeds very similarly. In fact the reasoning process behind this book can be applied to most computerized devices.

REASONING. That point leads to my next topic. Because of the detail I've presented, no one should read this book from cover to cover. I didn't plan to write a yarn, and I don't think I succeeded in doing so. Instead, this book should be read as needed. For this purpose, I indexed the first three chapters and alphabetized most of the fourth (a glossary). Section titles,

headlines and subheads can also be used to pinpoint relevant topics. This way you'll start with a brief section and follow the course of logic presented here in (1) reducing a symptom to its usual causes, (2) locating the problem and (3) solving it.

ACKNOWLEDGEMENTS. Reasoning alone didn't create this book. In many ways, you helped me write it. This is true because the procedures I explain are based on case histories. To this end, I used my technical experiences with customers' systems 4, 6, 7 and 8. Tom Cahill and other members of WILLIAMS' Customer Service Department helped me apply these experiences to System 9. WILLIAMS' service technicians also suggested the latest techniques, explained the new circuits and proposed refinements to several drafts of this book. Other assistance came from WILLIAMS' Engineering and Sales Departments. At various times I've consulted with game designers, programmers, quality inspectors and engineers, draftsmen and technicians. Hopefully these many viewpoints are so organized that most readers will find what they need. I especially want to thank Sebastian J. Ortega, James Ross and John H. Clark III for their cooperative efforts in producing illustrations for this book.

System-9 Games (in Chronological Order)

| NAME | PINBALL OR SHUFFLE? | GAME NO. | YEAR RELEASED | NOTES |
|---------------|---------------------|----------|---------------|--------------------------------------|
| STAR LIGHT | pinball | 530 | 1984 | Early STAR LIGHT games used system 7 |
| SPACE SHUTTLE | pinball | 535 | 1984 | |
| STRIKE ZONE | shuffle alley | 1916 | 1984 | |
| SORCERER | pinball | 532 | 1985 | |
| COMET | pinball | 540 | 1985 | |

CHAPTER 1 MECHANICAL SERVICING

Setup Procedures
Five-Minute Checkup
Weekly Service Program

Periodic, Major Procedures
Other Mechanical Adjustments

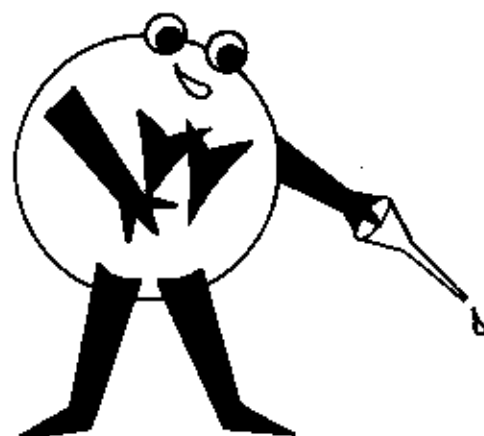

Setup Procedures

[] Install a playfield mylar or use a small, mylar protector above the game's flippers. (This area's the highest-wear spot on the playfield.)

[] Clean the playfield:

1. Use a non-abrasive compound to polish the playfield. Compounds by Wildcat, NuLook, Mills, Wico (and equivalents by other brands) do a fine job.
2. Never use soap or abrasive cleaners on the playfield; dirty areas should be cleaned with a damp rag.
3. USE WAX SPARINGLY! Don't get it on drop-target backup blades (T-springs): Built-up wax can easily foul your backup blades--and switches.
4. DROP TARGETS. While you're checking them, insure reliable operation from those drop targets! Clean them regularly. Then apply WILLIAMS' drop-target lubricant to your backup blades.

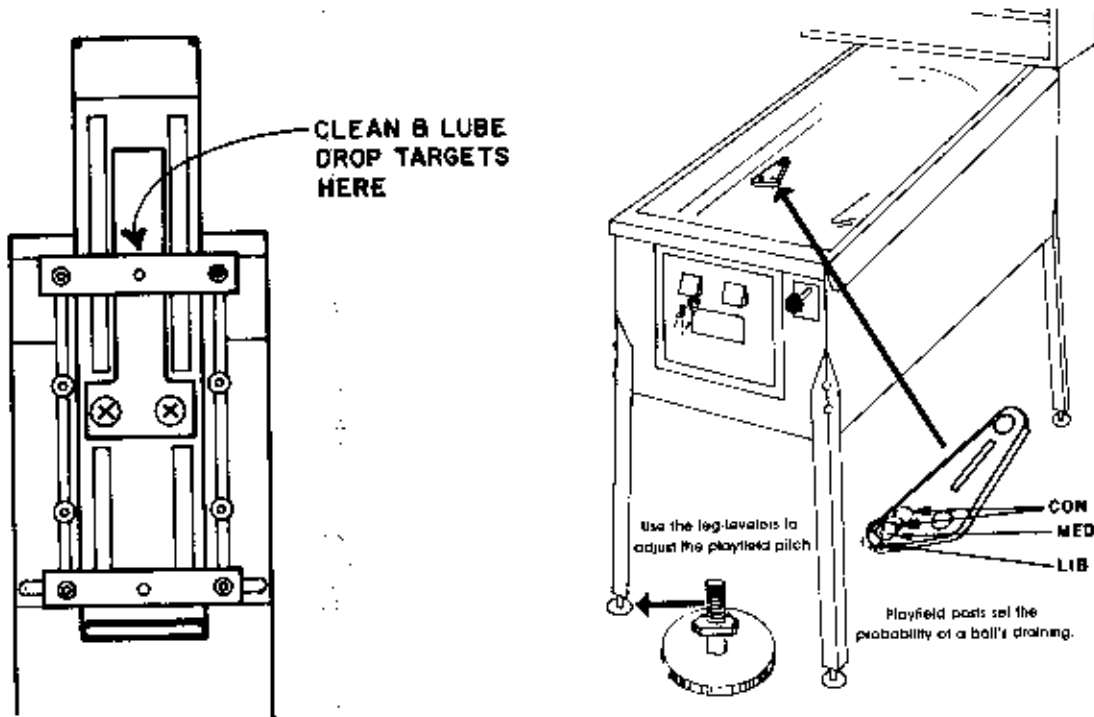

[] Clean the front of the backbox glass with window cleaner. Take care not to get the back of the glass damp, as the cleaner may lift up the artwork (usually painted on the back of the glass).

[] Adjust your game's mechanical difficulty by moving playfield posts. Also vary playfield pitch between 5 and 7 degrees to the floor. The pitch adjustment alters the action of the game: A steeper angle to the floor (7 degrees) offers players a greater challenge than a more gradual angle (5 degrees).

1. The game's electronic difficulty can also be modified by following game-adjustment instructions in your manual. Refer to the Game-Adjustment Table.

[] Tilt-mechanism adjustments

1. Don't forget to put the weight on the plumb-bob tilt!
2. Adjust the lead weight up (conservative setting, for tougher games) or down (liberal setting) with the thumbscrew provided. Remember that most players like to shake the machine a little; you should only make the wild ones tilt the machine. Check this adjustment every time you change the playfield tilt.

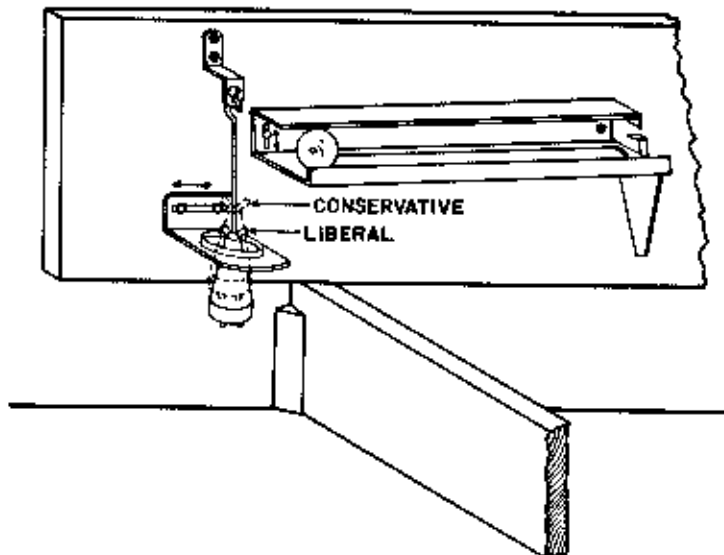

3. PLAYFIELD PITCH AND THE PLUMB-BOB RING... Always set pitch before adjusting ring position. Here's how: Adjust playfield pitch and then set the tilt's up-and-down position (as detailed above). Now slide the ring back and forth. You're done when you center the plumb bob in the ring.
4. YOUR SLAM-TILT SWITCH may become bent; be sure it's sensitive enough to protect your game from players who kick or bang on the machine. Prevent equipment damage! When you drop the machine from 1" off the floor it should indicate "GAME OVER" and "TILT".
5. YOUR BALL-ROLL TILT becomes less sensitive when the playfield pitch is adjusted upward (at a greater angle to the floor). Lift the cabinet one inch off the floor. The ball should slowly roll to the end of the track. When you lower the game the ball should return to its original position. Pushing the game shouldn't send the ball to the end of the track.

Five-Minute Checkup

- [] Run diagnostics. Are all the solenoids working? Are any lamps burned out? Hold down each switch while the machine makes at least two counting sounds. (Note: Allowing only one counting sound doesn't permit the machine to display shorted switches.) Be sure each switch registers correctly according to your game manual's switch-matrix drawing.

1. No two switches should have the same number; the only missing numbers should correspond to NOT USED switches!

- [] Run a handful of coins down your coin chutes.

- [] Oil the ball-shooter's plunger, the coin-return buttons and the cabinet-locking mechanism.
- [] Play a few games and see if the game offers a satisfying challenge. Is it all it can be, or will a few minutes worth of adjustments pay dividends later on?

Weekly Service Program

- [] Replace bad light bulbs.
- [] Clean or replace dirty rubber rings.
 1. Replace each rubber ring every three to six months (depending on how much the game is played).
 2. Size: A new ring looks smaller in your hand than when stretched over playfield posts. Get the right size ring for the job! A ring should never fit loosely on its posts.
 3. Check the rings you remove for cleaning: If they don't snap to a circular shape, then replace them.
- [] Check inside the backbox and cabinet for burned connectors.
- [] **ELECTROLYTIC CAPACITORS:** Also look for bulging or leaky capacitors on the power supply. Inspect the large cap on the main power board. A bad cap here means your game hasn't been working for some time! Others may affect the displays or the flippers. Replace such obviously bad parts. More on this in the chapter on electronic troubleshooting!

[] Switch cleaning:

1. PLAYFIELD LEAF SWITCHES...

With your thumb and forefinger, clamp the blades together. Now run a calling card between the contacts (You can substitute a dollar bill for the calling card).

2. FLIPPER SWITCHES. These include the EOS switch (on each flipper) and buttons (on the cabinet). Clean them with a flat file. Don't use a file on any other switch!

3. While cleaning switches, also check the drop targets for loose mounting screws and replace worn-out parts.

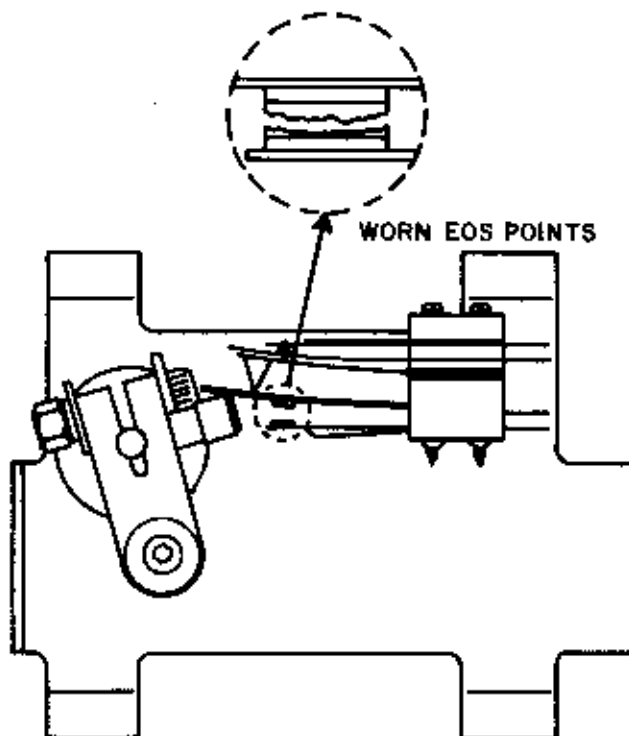

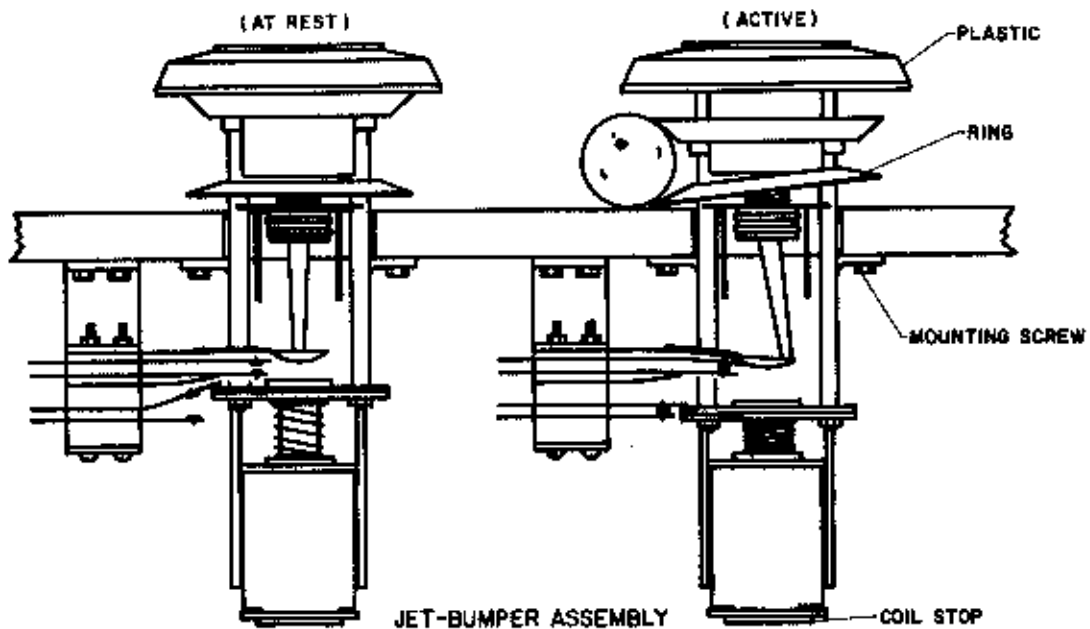

[] On jet bumpers, be sure the following are up to snuff:

1. rings: worn or broken?
2. plastics: cracked or chipped?
3. coil stops: broken, bent or cracked?
4. mounting screws: loose?

Periodic, Major Procedures

[] Flippers: Dismantle them. If your flippers are weak, that's how your profits will be! Make sure each part is good as new...

1. coil sleeves
2. coil stops
3. mounting brackets
4. playfield bushings: are they worn or cracked?
5. wiring and EOS switch
6. return spring
7. Flipper reassembly: Apply a non-hardening, thread-locking compound (Loctite brand, or equivalent) to coil-stop screws.

[] Restore a factory-fresh look to your classic playfields!

1. Classic games with a fresh appearance can earn like new games. Paint the worn spots before you re wax that crowd-pleasing playfield!

Other Mechanical Adjustments

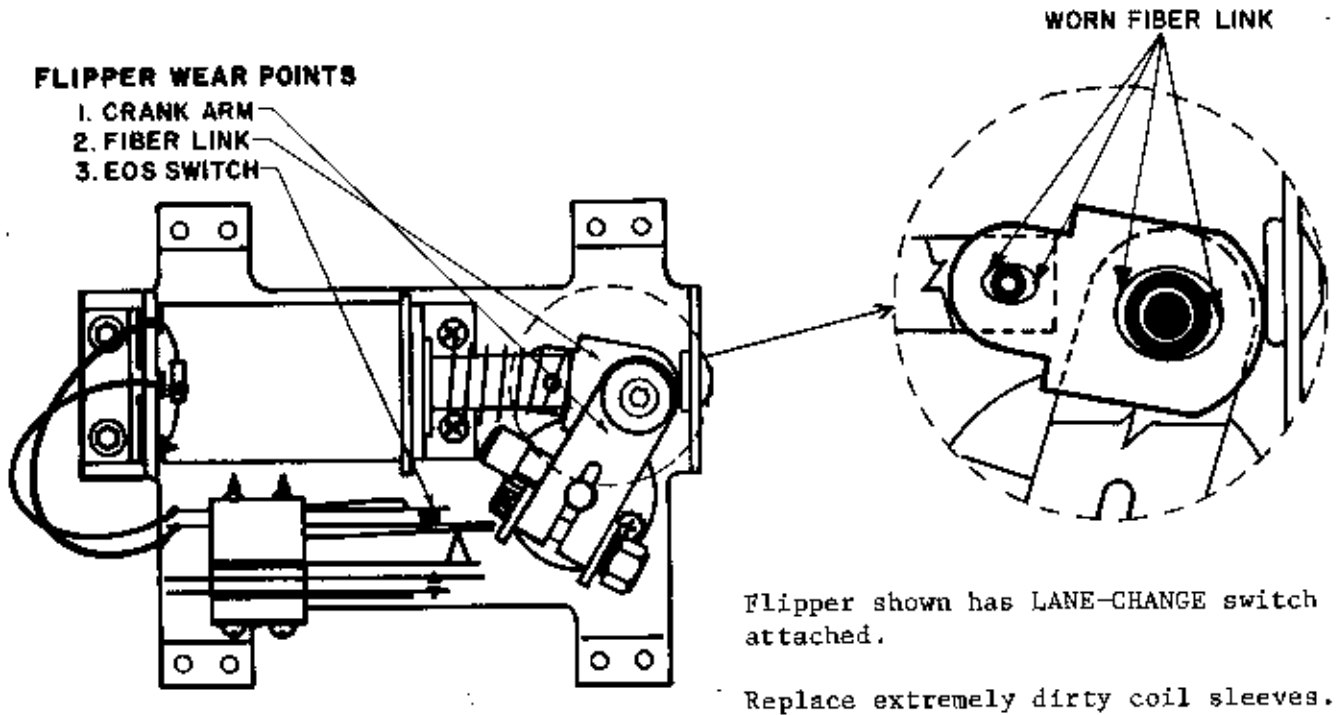

- * If your fiber links are this badly worn, your flipper coils are probably open too! Here's why... Extreme fiber-link wear (as shown) prevents the crank arm from operating the EOS switch. This situation causes flipper-coil burnout.
- * Look for cracks where the bolt tightens on the flipper shaft.
- * Examine your crank arm. You may find cracks where the crank arm actuates the EOS switch.
- * Check the insulation on your EOS actuator. There should never be metal-to-metal contact between crank arm and EOS switch!

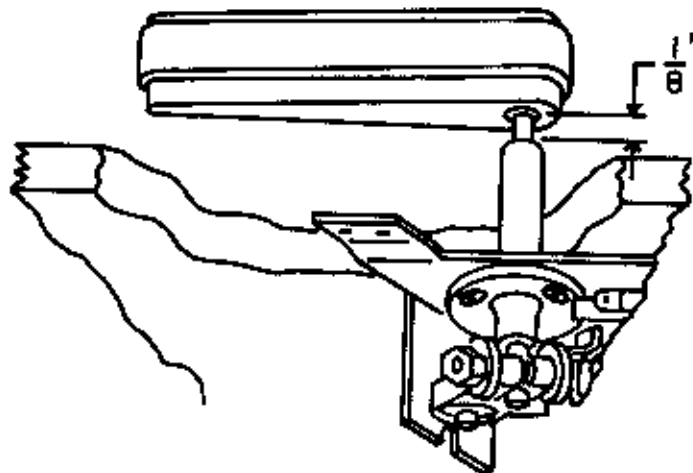

- * Distance between sleeve and bottom of flipper paddle should be 1/8 inch:

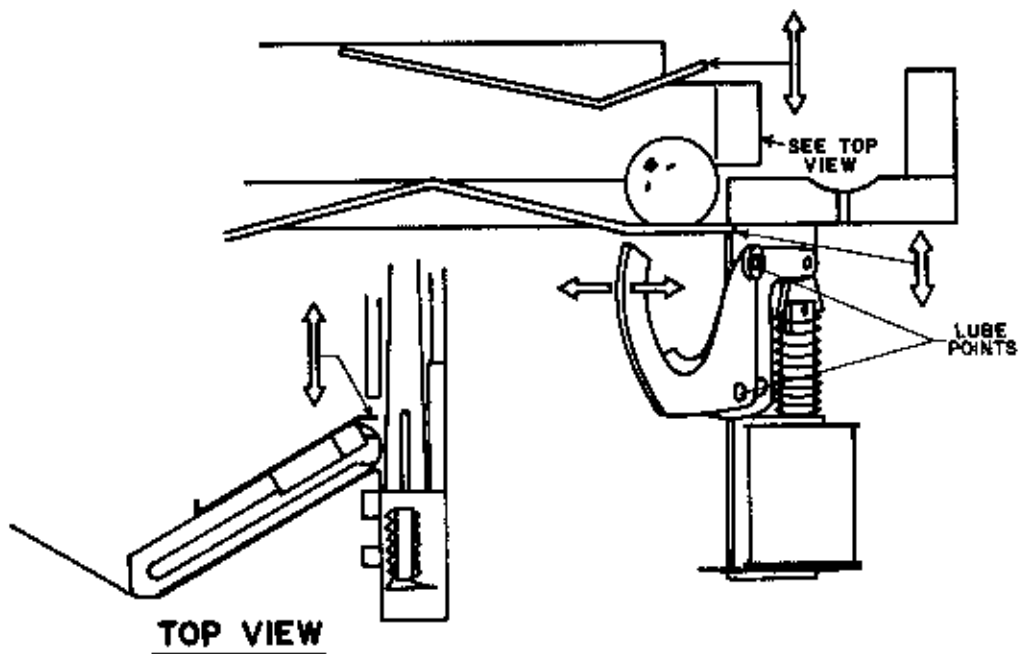

* Adjustable features on an eject hole (This type of eject hole is used in MULTI-BALL games.)

[] Lubrication points

1. drop-target blades
2. spinning-target pivot points
3. eject, kicker and flipper crank-arm assemblies

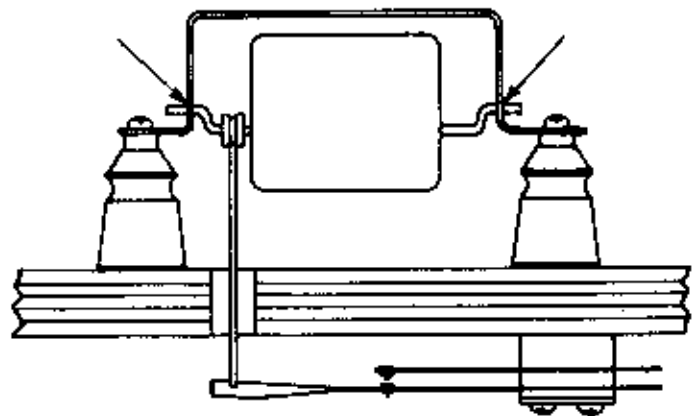

* Lubrication points on spinning targets

[] Adjusting Leaf Switches (used on jet bumpers, kickers, etc.)

1. Only qualified technicians should adjust switches.
2. Adjustments must be made with the power off.
3. Before you adjust them, tighten the stack!
4. Use a blade-adjustment tool or very long-jawed needlenose pliers.
5. For more liberal play, carefully bend the backup blade toward the moving contact. For more conservative play, adjust the backup blade away from the moving contact.
6. Take care not to disable the switch by over or under-gapping it. With a ball, activate the switch several times to see if it registers properly.

7. Adjust switches on standup targets, jet bumpers, rollovers and spinners from the bottom of the playfield. Adjust switches on kickers from the top of the playfield.
8. Before you release the machine to a location, turn it on and play. How are the switches performing? Double-check your adjustments: Run the switch test described in your service manual.

[] Adjusting Microswitches (used on ball trough, eject hole)

1. Only qualified technicians should adjust switches.
2. Adjustments must be made with the power off.
3. To increase or decrease sensitivity, move the body of the microswitch. Don't bend the blade (as with leaf-switch adjustments).

CHAPTER 2. USING THE PUBLICATIONS

Game-Registration Card
Bookkeeping and Game-Adjustment Tables
Lamp-Matrix Chart

Switch-Matrix Chart
Solenoid Chart



Game-Registration Card

AN OPEN CHANNEL. Your game-registration card is your open channel to the factory. We read every card and we consider every suggestion. So please take a few moments to tell us how your new game's performing! This is more than a chance to put your two cents in. Your comments (positive and negative) help us improve the quality, performance and user-friendliness of our games. Try to keep your words neat, concise and to the point. This way you'll be sure we understand your card.

Bookkeeping and Game-Adjustment Tables

SET UP YOUR GAME FOR PROFITS. There's no better way to start than a spin through your Bookkeeping Table and Game-Adjustment Table. Do this at least once a week. First, follow your manual's instructions and put your game into Bookkeeping Mode. Now the game uses its five gas-discharge displays to communicate. Without your manual, the displays seem to present an endless stream of meaningless numbers. Make no mistake. These are vital statistics. That's why you need the manual as an interpreter!

VITAL STATISTICS. In fact, Bookkeeping Mode tells you everything you need to know about your players... How many coins did they spend on your game? How did they score? How long did they play? How many replays, specials, extra balls and other features did they achieve? These facts help you tailor your game to your players. That means more enjoyment for them...and more profits for you.

ADJUSTMENTS. Of course that leads us to the Game-Adjustment Table. Your manual tells you how to display each adjustment's function number and what each number means. With the book to guide you, you'll be able to adjust that game to alter replay levels, boost or reduce playtime, and render game features harder or easier to achieve (as well as more or less rewarding)!

Lamp-Matrix Table

NOT ALL LAMP PROBLEMS are as simple as changing bulbs. When you're maintaining a few pinball games, you'll need a quick way to analyze those lamp circuits. It's here! Your instruction manual's Lamp-Matrix Table helps you identify the wiring and CPU-board connections to a bad lamp circuit.

HERE'S HOW... Follow your manual's instructions about the lamp test. Now refer to the Lamp-Matrix Table. Identify the bad lamp by name and the table can tell you what lamp column and row this lamp is wired into. Maybe you'll find that all the lamps in one column are out. The CPU-board connector and pin numbers for that column are given on the chart (1J7-8, for example).

NOW YOU CAN TROUBLESHOOT the circuit attached to that connector and pin (connector 1J7, pin 8). Use your CPU-board drawing (sheet 2 of 3) and check the circuit for strobe (column) 7. You can solve row problems the same way, since row connectors are also given on the Lamp-Matrix Table.

NOTICE: These typical matrix tables are from the SORCERER game. Each game has a different layout, so each game's tables are unique.

System 9 Lamp-Matrix Table

| COLUMN ROW | 1 YEL-BRN 1J7-1 | 2 YEL-RED 1J7-2 | 3 YEL-ORN 1J7-3 | 4 YEL-BLK 1J7-4 | 5 YEL-GRN 1J7-6 | 6 YEL-BLU 1J7-7 | 7 YEL-VIO 1J7-8 | 8 YEL-GRY 1J7-9 |
|-----------------------|---------------------------|-----------------------|-----------------------|--------------------------|-----------------------|-----------------------|------------------------|------------------------------|
| 1 RED-BRN 1J6-1 | Game Over Lamp 1 | S 9 | A 17 | Right Drain 25 | 1 33 | 9 41 | 2X 49 | Backglass Effect 57 |
| 2 RED-BLK 1J6-2 | Match 2 | O 10 | B 18 | Left Flipper Ret. 26 | 2 34 | 10 42 | 4X 50 | Backglass Effect 58 |
| 3 RED-ORN 1J6-3 | Tilt 3 | R 11 | C 19 | Right Flipper Ret. 27 | 3 35 | 20 43 | 6X 51 | Backglass Effect 59 |
| 4 RED-YEL 1J6-5 | High-Score-To-Date 4 | C 12 | D 20 | All Scores 2X 28 | 4 36 | 30 44 | 8X 52 | Backglass Effect 60 |
| 5 RED-GRN 1J6-6 | Shoot Again (Insert) 5 | E 13 | Extra Ball 21 | All Scores 3X 29 | 5 37 | 40 45 | Left Drop-Tgt 53 | Backglass SORCERER art 61 |
| 6 RED-BLU 1J6-7 | Ball-In-Play 6 | R 14 | Bonus Hold Over 22 | All Scores 5X 30 | 6 38 | 50 46 | Center Drop-Tgt 54 | Backglass SORCERER art 62 |
| 7 RED-VIO 1J6-8 | Shoot Again (Pfid) 7 | E 15 | Demon 23 | Light Below "S" 31 | 7 39 | Lock 47 | Right Drop-Tgt 55 | Backglass SORCERER art 63 |
| 8 RED-GRY 1J6-9 | Play-field Special 8 | R 16 | Left Drain 24 | Light Below "R" 32 | 8 40 | Release 48 | Backglass Effect 56 | Backglass SORCERER art 64 |

System 9 Switch-Matrix Table

| COLUMN ROW | 1 GRN-BRN 1J8-1 | 2 GRN-RED 1J8-2 | 3 GRN-ORN 1J8-3 | 4 GRN-YEL 1J8-4 | 5 GRN-BLK 1J8-5 | 6 GRN-BLU 1J8-7 | 7 GRN-VIO 1J8-8 | 8 GRN-GRY 1J8-9 |
|------------------------|-----------------------|-----------------------|-----------------------|-----------------------|-----------------------|-----------------------|-----------------------|-----------------------|
| 1 WHT-BRN 1J10-9 | Plumb-Tilt 1 | Left Spinner S 9 | A 17 | Right Drain 25 | Right Kicker 33 | Not Used 41 | Not Used 49 | Not Used 57 |
| 2 WHT-RED 1J10-8 | Ball-Hall Tilt 2 | O 10 | B 18 | Left Flpr Ret. 26 | Left Drop-Tgt 34 | UPR-L Switch 42 | Not Used 50 | Not Used 58 |
| 3 WHT-ORN 1J10-7 | Credit Button 3 | R 11 | C 19 | Right Flpr Ret. 27 | Center Drop-Tgt 35 | Lane Switch 43 | Not Used 51 | Not Used 59 |
| 4 WHT-YEL 1J10-6 | Right Coin 4 | C 12 | D 20 | Outhole 28 | Right Drop-Tgt 36 | Lane Change 44 | Not Used 52 | Not Used 60 |
| 5 WHT-GRN 1J10-5 | Center Coin 5 | E 13 | Left Jet 21 | Ramp 1 29 | Multi-Ball Ramp 37 | Play-Field Tilt 45 | Not Used 53 | Not Used 61 |
| 6 WHT-BLU 1J10-3 | Left Coin 6 | R 14 | Lower Jet 22 | Ramp 2 30 | Multi Ball SW 38 | Not Used 46 | Not Used 54 | Not Used 62 |
| 7 WHT-VIO 1J10-2 | Slam Tilt 7 | E 15 | Right Jet 23 | Shooter Lane SW 31 | Lower Right SW 39 | Not Used 47 | Not Used 55 | Not Used 63 |
| 8 WHT-GRY 1J10-1 | High-Score Reset 8 | Right Spinner R 16 | Left Drain 24 | Left Kicker SW 32 | Lower Left SW 40 | Not Used 48 | Not Used 56 | Not Used 64 |

Switch-Matrix Table

SWITCH PROBLEMS ARE COMMON. But you have the key that unlocks them. Like your Lamp-Matrix Table, the Switch-Matrix Table helps you identify the wiring and CPU-board connections for bad circuitry.

SWITCH TEST... Follow your manual's instructions and initiate the switch test. Now refer to the Switch-Matrix Table. Identify the bad switch by name and the table can tell you what switch column and row this switch is wired into. Maybe you'll find that the switches in one row never work. The CPU-board connector and pin numbers for that row are given on the chart (1J10-6, for example).

TEST THE CIRCUIT attached to that connector and pin (connector 1J10, pin 6). With your CPU-board drawing (sheet 2 of 3), check the circuit for switch-matrix input (row) 4. You can solve column problems the same way, since column connectors are also given on the Switch-Matrix Table.

Solenoid Table

WHAT IT IS... Your Solenoid Table is a unique source of information on your game's coils. If you want to order a replacement part, it tells you the number. If you need to know in what order the solenoids are pulsed during the Test Mode (what number the game assigns to each coil); the table tells you that. Of course it gives wire colors and connector numbers. But it even tells you the number of the solenoid-driver transistor back on the CPU board.

HOW DO I USE IT? Let's say solenoid #1 refuses to pull in. But we know this coil's okay since we've just replaced it. No problem. Consulting the Solenoid Table we find that solenoid #1 is connected to Q47 on the CPU board. Over on sheet 2 of 3 of your CPU-board drawings you find out that Q47 is a TIP122 transistor. Your CPU-Board Assembly Drawing helps you locate the part on the board so you can test it.

Typical Solenoid Table

| SOL. NO. | FUNCTION | SOLENOID TYPE | WIRE COLOR | CONNECTIONS | | DRIVER TRANS. | SOLENOID PART NO. |
|----------|----------------------|---------------|------------|-------------|---------------|---------------|------------------------|
| | | | | CPU | PLAYFIELD | | |
| 01 | Outhole | controlled | GRY-BRN | 1J11-1 | 8P3-1 | Q47 | AE-23-800-01 |
| 02 | Drop Target | controlled | GRY-RED | 1J11-3 | 8P3-2 | Q48 | SA-5-24-750-DC |
| 03 | "A-B-C" Eject Hole | controlled | GRY-ORN | 1J11-4 | 8P3-3 | Q49 | AE-23-800-03 |
| 04 | "ZAP!" Flashers | controlled | GRY-YEL | 1J11-5 | 8P3-4 | Q50 | #63 flashlamps |
| 05 | "POW!" Flashers | controlled | GRY-GRN | 1J11-6 | 8P3-5 | Q39 | #63 flashlamps |
| 06 | "X-Y-Z" Eject-Hole | controlled | GRY-BLU | 1J11-7 | 8P3-6 | Q40 | AE-23-800-D3 |
| 07 | Player-1 Flashers | controlled | GRY-VIO | 1J11-8 | 8P3-7 | Q41 | #63 flashlamps |
| 08 | Player-2 Flashers | controlled | GRY-BLK | 1J11-9 | 8P3-8 | Q42 | #63 flashlamps |
| 09 | Player-3 Flashers | controlled | BRN-BLK | 1J12-1 | 8P3-9 | Q54 | #63 flashlamps |
| 10 | Player-4 Flashers | controlled | BRN-RED | 1J12-2 | 8P3-10 | Q55 | #63 flashlamps |
| 11 | General Illumination | controlled | BRN-ORN | 1J12-4 | 3P7-1 | Q56 | 5580-09555-00 |
| *12 | Not Used | controlled | BRN-YEL | 1J12-5 | 8P3-12 | Q57 | - |
| 13 | Not Used | controlled | BRN-GRN | 1J12-6 | 8P3-13 | Q58 | - |
| 14 | Not Used | controlled | BRN-BLU | 1J12-7 | 8P3-14 | Q59 | - |
| 15 | Knocker | controlled | BRN-VIO | 1J12-8 | 7P1-17 | Q60 | AE-23-800-07 |
| 16 | Coin-Lockout Coil | controlled | BRN-GRY | 1J12-9 | 7P1-18, 7P2-4 | Q61 | SM-35-4000-DC |
| *17 | Left Kicker | special #1 | BLU-BRN | 1J19-7 | 8P3-17 | Q75 | AE-23-800-03 |
| *18 | Right Kicker | special #2 | BLU-RED | 1J19-4 | 8P3-18 | Q77 | AE-23-800-03 |
| *19 | Upper Jet-Bumper | special #3 | BLU-ORN | 1J19-3 | 8P3-19 | Q79 | AE-23-800-03 |
| *20 | Left Jet-Bumper | special #4 | BLU-YEL | 1J19-6 | 8P3-20 | Q81 | AE-23-800-03 |
| *21 | Lower Jet-Bumper | special #5 | BLU-GRN | 1J19-8 | 8P3-21 | Q83 | AE-23-800-03 |
| *22 | Right Jet-Bumper | special #6 | BLU-BLK | 1J19-9 | 8P3-22 | Q85 | AE-23-800-03 |
| - | Flipper (Not Used) | - | BLK-BLU | 1J19-2 | 7P1-30 | - | - |
| - | Right Flipper* | - | ORN-VIO | 1J19-1 | 7P1-7 | - | FL23/600-30/2600-50VDC |
| - | Left Flipper* | - | ORN-GRY | 1J19-2 | 7P1-9 | - | FL23/600-30/2600-50VDC |

CHAPTER 3. ELECTRONIC AND
ELECTROMECHANICAL TROUBLESHOOTING

A Word On System Architecture
Pinouts for 6802 and 6808 Microprocessors

System 9 and the 6802/6808 Microprocessor
Electronic Service Procedures
Diagnosing Common Symptoms

Linear Power Supplies
Flippers
Switch Problems

Playfield Coils
Lamps
Displays

Sounds
Power, Bus and Clock Problems
Speech Board

NOTICE

INDEX. This chapter is indexed. If you're interested in troubleshooting a particular symptom, turn to the Index at the back of this book. The index will lead you to the pages concerned with your game's apparent malfunction.

NON-SYSTEM-9 GAMES. When examples of circuitry are appropriate, this chapter frequently refers to System 9. Applying the explanations to other WILLIAMS games is easy. Use the book's theory drawings, block diagrams and other illustrations to guide you through similar (if not identical) circuitry in your game. Be alert, as part callouts differ from system to system. Those with System-11 games may consult the conversion table in Chapter 4. This table converts System-9 part callouts to System-11 callouts. The table follows the text.

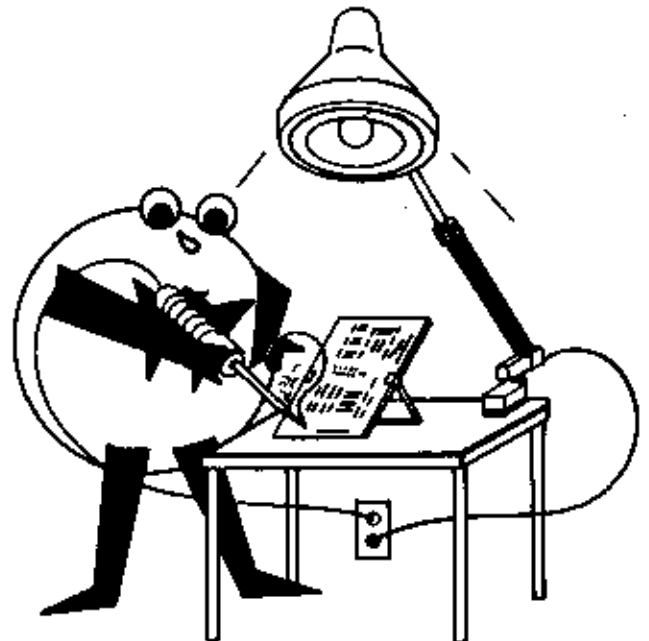

A Word On System Architecture

YOUR PINBALL MACHINE IS A COMPUTER. It's as complex as most personal computers. If you want to perform serious repairs, you must understand its block diagram. Troubleshooting should flow from block diagram to schematic. Follow this easy procedure... (1) When the game malfunctions, try to deduce which block contains the problem. Remember, usually only one part of a circuit breaks. (2) Next examine the contents of the block. Using schematics, establish which part of a block is probably faulty. (3) Locate the damage. You only need to test a few circuits!

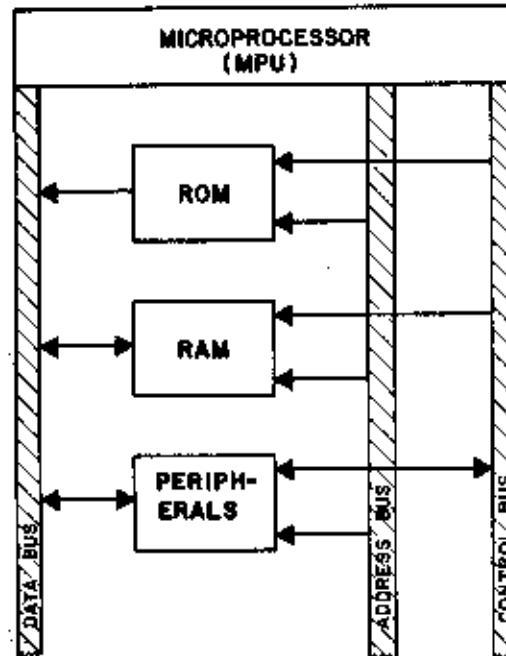

COMMON FEATURES. Modern computers have certain common features. In 1945 John von Neumann conceived what we know today as the digital computer. While other designs (or architectures, as they're known) are also being used, most computers follow von Neumann's model. Your game is no exception.

MICROPROCESSOR. Like all computers, your pinball machine has an on-board silicon brain that processes and controls data according to a set of internal instructions. These instructions are called microcode, and they're stored in the brain chip which is called the microprocessor.

TEMPORARY MEMORY. Why does a computer need memory? One reason is that data must be stored temporarily until the microprocessor's ready to use it. Temporary storage is provided by random-access memory (RAM) chips. The microprocessor can write instructions into RAM, and then read the instructions later. This is why RAM chips are often called read-write memories. Two examples of temporarily-stored data are your game adjustments and bookkeeping totals. This information is stored in your game's CMOS RAM.

PERMANENT MEMORY. Actually even with temporary memory, a computer is just useless hardware. Unlike other machines, a computer can't function without a set of instructions known as a program or software. In fact most of your game is software. Only by consulting its program does the microprocessor know which game to play and how to play it.

Permanent memory in the form of read-only memory (ROM) chips is used to store the game program. This then is the big distinction between RAM and ROM: The microprocessor can read the program in ROM, but it can't write into ROM. Any writing the microprocessor does will appear in one of the game's RAM chips (or in smaller temporary memory units called flip-flops, latches and registers).

There are various types of ROMs known as PROMs, EPROMs, EAROMs and EEROMs. The commonest one used in pinball games is the erasable, programmable read-only memory (EPROM). At our factory we program ("burn") EPROM chips with game software. Successfully burned EPROMs are referred to as firmware since they're both hardware (ROM) and software (program).

PERIPHERALS. So far we're in the backbox of your game. But we haven't emerged onto the playfield yet! What about drop targets? What about lanes, playfield specials, displays, sounds, speech, rollovers and all that? Every computer must have at least one input device and one output device. And true to form, some of these examples involve information the player sends the computer (rollover switches), while some involve information the computer sends the player (displays). But to your game computer these are all peripherals.

Your game's peripheral-interface adapter chips (PIAs) serve as input-output ports (I/O ports). Their job is to connect the game to the outside world. They do this by controlling and sensing peripherals on the playfield, in the cabinet and on the backbox door. This category even includes sounds and speech, which are produced by a slave computer on the CPU board.

OTHER PARTS... Now we know the basic four parts of your game computer...(1) microprocessor, (2) temporary memory or RAM, (3) permanent memory or ROM and (4) peripherals. But when these four blocks operate together, three other features are necessary: A clock, a bus structure and a power supply.

CLOCK. Since all computer operations must be timely and coordinated, a means of synchronization is necessary. This is called the clock or crystal clock. It provides the pinball computer with a constant source of clean square waves. The microprocessor uses these pulses to pace itself. For example, this chart demonstrates how an imaginary computer might operate...

| CLOCK CYCLE | HERE'S WHAT THE MICROPROCESSOR DOES... |
|-------------|--|
| 1 | * identifies address of next instruction |
| 2 | * addresses ROM; fetches data (instruction) stored at that address |
| 3 | * executes instruction |
| 4 | * writes result of operation into RAM or peripheral device |

THE BUS CONCEPT. When you study your pinball schematics, you'll notice that chips on the CPU board (as well as other boards) are connected together by an address bus, a data bus and sometimes a control bus. These bus structures are actually traces on printed circuit boards. They're the telephone lines that allow memory, peripheral and microprocessor chips to communicate. Damage to any of the three buses will completely disable your pinball machine.

The data bus (eight lines or bits) allows two-way communication. Meanwhile the address bus (16 lines or bits) is for one-way communication. It only permits the microprocessor to transmit addresses.

There may also be a control bus for selecting memory or peripheral devices through the address-decoder chip. (For example our system uses a 74LS139 decoder chip to select Game-ROM 1 or Game-ROM 2.)

POWER SUPPLY. Every electronic and electromechanical feature of your game requires power. Various voltages are used. Some of the most important are these... The microprocessor and logic system operate on regulated +5VDC. The digital-to-analog converter (DAC) chip in the sound section also requires -12VDC. The reset circuit uses +12VDC. Displays, controlled lamps and solenoids require various higher voltages. General-illumination lamps run off AC.

Because it's under such diverse stress from all these sources, the power supply's more likely to develop failures than any other circuit in your game. But if you suspect a power-supply failure, remember this... Since different parts of the game operate off different voltages, failing components can give you a clue as to which section of the power supply to check. For example, when all displays are out, we check the +100VDC and -100VDC supplies. If the sounds are missing, we check the -12VDC supply.

Pinouts for 6802 and 6808 Microprocessors

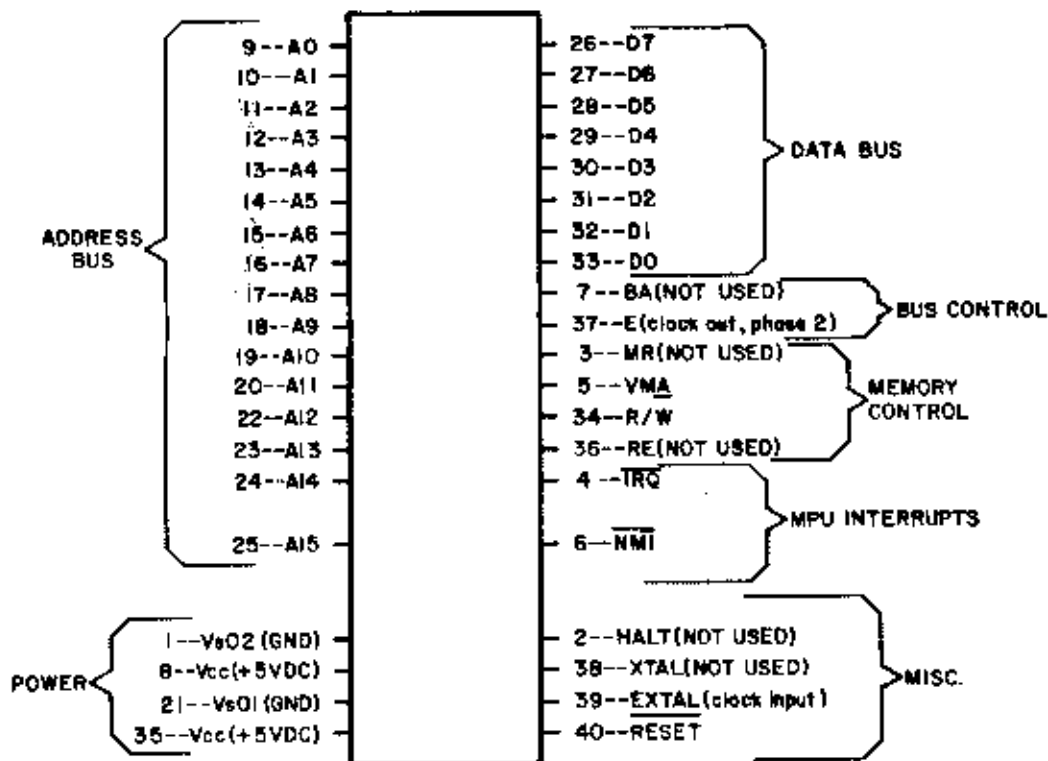

WILLIAMS' SYSTEM 9

(CONTROL BUS, POWER SUPPLIES AND ADDRESS DECODER NOT SHOWN)

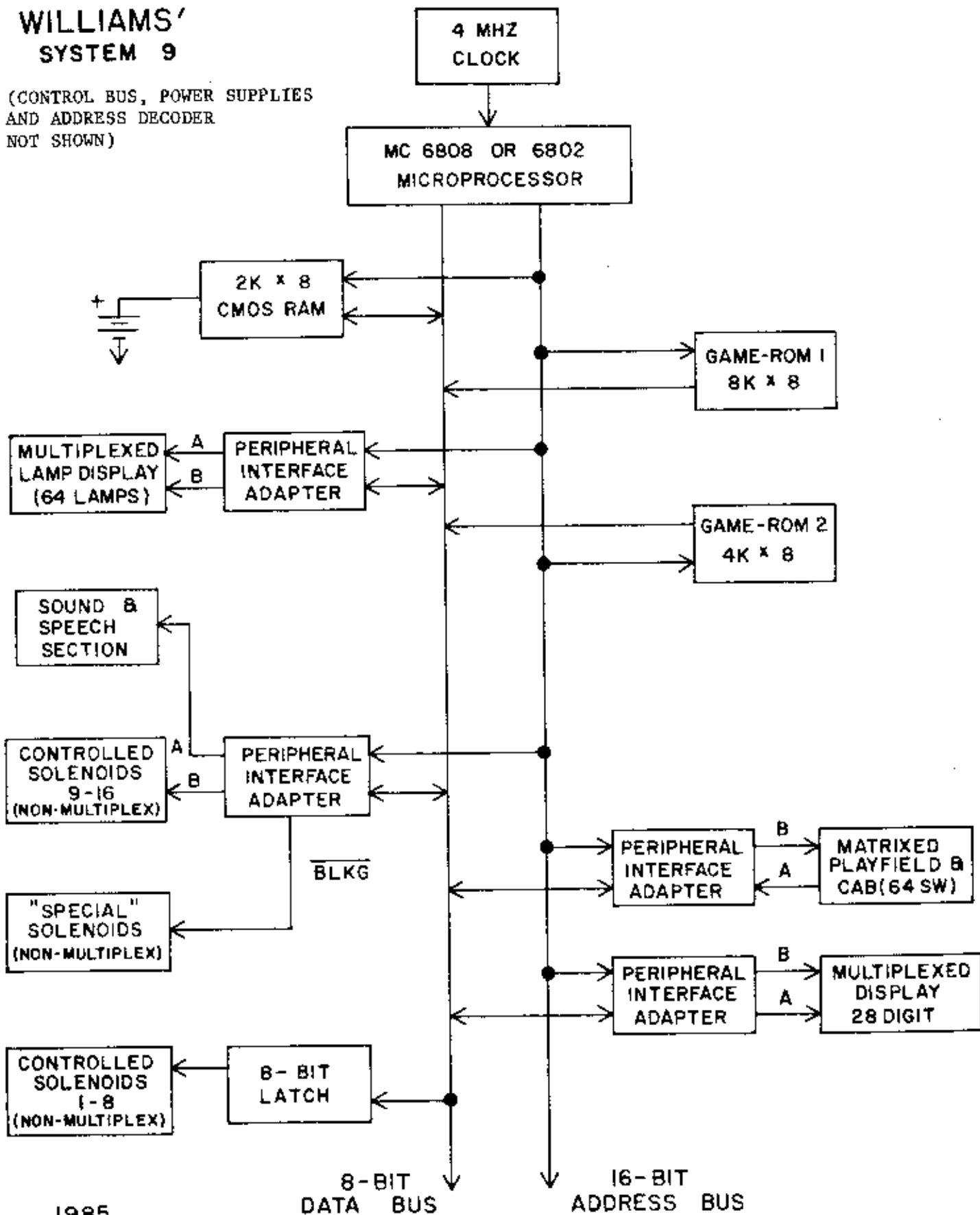

WILLIAMS' SOUND & SPEECH SECTION FOR SYSTEM 9

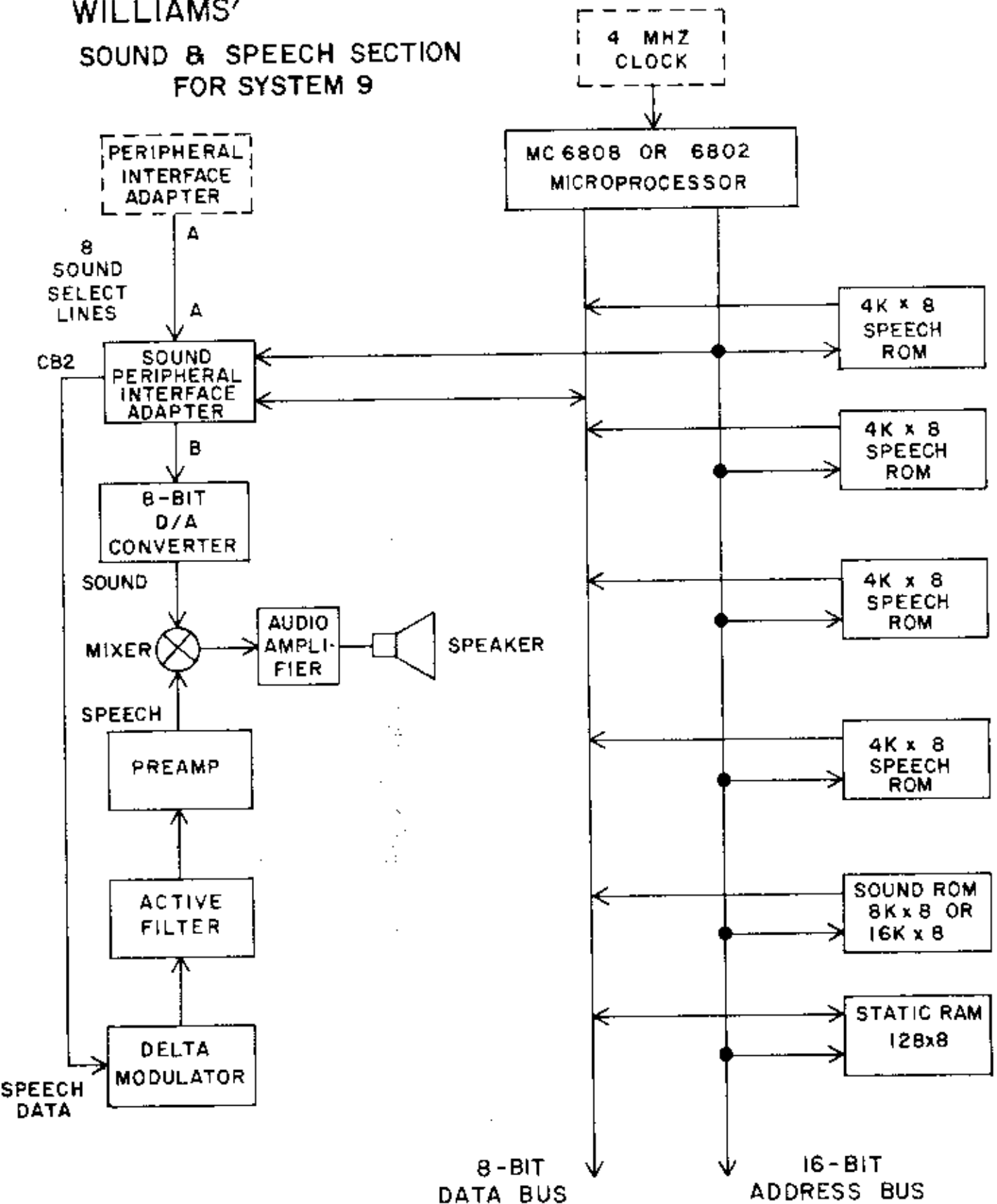

1985

(CONTROL BUS, POWER SUPPLIES AND ADDRESS DECODER NOT SHOWN)

System 9 and the 6802/6808 Microprocessor

DIGITS AND VOLTS. To your microprocessor, voltages represent the binary digits "1" and "0." As may be expected, "0" translates to 0VDC. Because a voltage is used, technicians often refer to the "0" signal as a "low pulse," "low logic level" or merely "low." However "1" implies 5VDC or "high".

SOURCE CODE (the game's program) is written in assembly language. The factory's assembler software converts the source code into object code for your microprocessor. Object code consists solely of binary numbers. Each number denotes an instruction, an address, data, etc.

ADDRESS BUS. 6802 and 6808 microprocessors have an address bus composed of 16 lines or bits. The bus permits your microprocessor to directly address 65,536 memory locations (two to the sixteenth power). This number is abbreviated "64K." Programmers refer to your microprocessor's highest address as FFFF (hex for 65,536). Each memory address is one byte long. One byte of data may be stored there. Such locations exist in PIA, RAM and ROM chips. System-11 computers use all their address lines to access 64K memory locations. But System-9 computers only use the lower 15 address lines. That means their highest address is EFFF, or 32,768.

BIDIRECTIONAL DATA BUS. Your microprocessor's data bus has eight lines (bits). Two to the eighth power, or 256 different data bytes can travel on this bus. The data bus is bidirectional. However data may only travel in one direction at a time. Your microprocessor regulates data direction either away from or toward your microprocessor. If your microprocessor fails, data may travel in both directions at once. A short (simultaneous low and high) may occur. But in the event of a short, your power supply's fuses limit damage.

TASKS AND INTERRUPTS. The microprocessor performs two types of tasks. These are ongoing operations (data processing) and interrupt-service routines. Interrupt routines are the more interesting tasks because they involve the computer's interaction with the player.

REAL TIME. The microprocessor's ongoing tasks can be interrupted to service peripherals. This is so because unlike the microprocessor, a peripheral works on real time. That is, data (scores, switch closures on the playfield, etc.) would be lost if the microprocessor ignored a peripheral's interrupt routine.

INTERRUPT CLOCK. When servicing most peripherals, your game uses the interrupt-request-not (IRQ) signal. (Another signal is used for display refreshment.) System 9's counter U10 and feedback gate U38 divide the 1MHz E-clock by 1,000. (System-11 uses chips U29, U35 and U36.) This circuit is called the interrupt clock. It produces the 1 kHz IRQ (interrupt request-not) signal at the microprocessor's IRQ pin. IRQ is an "active low" signal. Once every millisecond, IRQ goes low. The microprocessor interrupts ongoing operations to service input ports (scan switches).

INTERRUPT VECTOR. Imagine that a scoring switch is made. Here's what happens... The interrupt clock pulses low. Next the microprocessor loads (reads) an "interrupt vector" from ROM. This two-byte vector contains the starting address of the interrupt service routine. The service routine allows scoring information from the switches to be periodically updated or

refreshed. The interrupt clock (rather than the PIA) automatically controls the update process. For this reason, the process is known as "dynamic refreshment."

READING. Scorekeeping involves reading. During an interrupt the microprocessor stores its current routine. Next the microprocessor addresses the scoring switch's PIA location. Then the microprocessor reads the value at that address ("1" means "closed scoring switch" and "0" means "open scoring switch"). This value is stored (written) in RAM so the microprocessor can resume its original routine.

WRITING. Suppose the microprocessor has to pulse a controlled solenoid. Here's the whole procedure:

- (1) Using the control bus, the microprocessor enables the solenoid's PIA.
- (2) Again using the control bus, the microprocessor pulls the read-write (R/W) line low. This low pulse corresponds to a "write" command.
- (3) Using the address bus, the microprocessor addresses the solenoid's PIA location.
- (4) Using the data bus, the microprocessor writes a number to the step-3 address.
- (5) The PIA responds by enabling the solenoid.

DEVICES BEYOND MICROPROCESSOR CONTROL. Is anything on a modern pinball game outside the realm of computers? Actually about half the game is controlled by more direct means... (1) "Special" (switch-triggered) solenoids are a good example. These include kickers and jet bumpers. (2) The flippers are obviously controlled by buttons on the outside of the cabinet. After the processor sends the GAME-UP signal, special solenoids and flippers are activated by switches. (3) Many games don't use the general illumination relay. In these games, the general illumination too is beyond the jurisdiction of the microprocessor. (4) Of course power supplies aren't microprocessor controlled.

Electronic Service Procedures

CAUTION

POWER-SUPPLY. When servicing locked-up games or games that refuse to enter Game-Over Mode, always check the power-supply voltages at the CPU board (chip U17, pins 35 or 8) before proceeding. Be sure that the +5VDC supply is within 5% of its rated output (4.8V-5.2V). If it doesn't fall within this tolerance, you MUST repair or replace the power supply before continuing. Failure to do so may damage your machine.

CAUTION

* SOLDERING & DESOLDERING. In several places the following section suggests removing or desoldering components. Only qualified technicians using appropriate equipment should perform soldering or desoldering operations. Improper soldering will destroy your PC boards.

* NEVER USE A SOLDERING GUN. A 30W soldering pencil is the largest you should use on printed circuitboards. Never use an iron or pencil that's been used with acid-core solder.

* 60/40 SOLDER. Never use acid-core solder on your circuitboards or other electronic applications. Always use 60/40 solder for this purpose. Acid-core solder (and soldering tools that have previously been used with acid-core solder) will corrode wiring and PC traces.

CAUTION

GROUND THE PCB. Prevent electrostatic-discharge damage! Before you remove parts from a printed circuitboard, ground the board. You should also be grounded. Use a soldering-station wrist strap. (These shunt electric charges to ground before they discharge through circuitry. A current-limiting 1M resistor offers protection in case you accidentally contact a high-voltage source.) If you work on a grounded metal surface, remove the batteries before setting down a CPU board. Otherwise the batteries will short.

CAUTION

* USE SOCKETS. Reduce the chance of heat damage to replacement ICs! Socket your replacement part.

* MAJOR WORK... Where chips with more than 8 pins (especially PIAs, 74154 decoders, etc.) must be replaced, refer servicing to your authorized WILLIAMS distributor.

CAUTION

GROUND SOURCE FOR TESTING. You'll need a convenient ground point for power-on tests. Often you can use the backbox circuitboard panel. It's connected to power-line ground. Circuitboard mounting screws are also grounded. However many technicians ground to the bare, braided wire under the playfield. If you use this wire, beware of similar (but narrower gauge) wire under the playfield. The narrower braid carries 6.3VAC to general-illumination lamps. This AC will destroy logic circuitry.

NOTICE

ELECTRONIC TEST EQUIPMENT. This section makes certain assumptions about the diagnostic equipment you'll use to troubleshoot your game. Logic levels in +5VDC-powered circuits should usually be tested with a logic probe. Other measurements should be taken with a DVM, FET VOM, or VTVM. Bench technicians may substitute an oscilloscope for either a DVM or logic probe.

Diagnosing Common Symptoms

SYMPTOM: MY GAME... TESTS & PROCEDURES

Has a "7" on its LED readout

- [] Check for pulsing at any data pin of microprocessor-chip U17 on the CPU board. If pulsing is absent, check the solder joint on crystal U21 and capacitor C41. These components may also be defective.

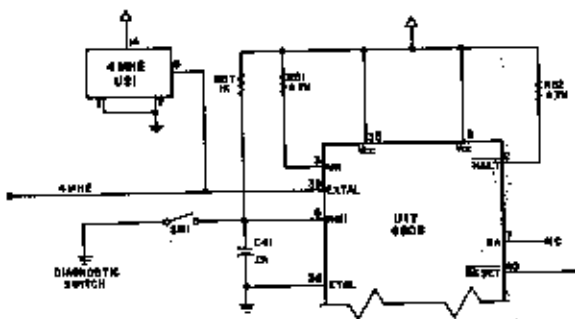

-
- Is stuck in Bookkeeping Mode: [] Is 3.5V or more present at CMOS-RAM U18, pin 24 when the game's turned OFF? If not...
- [] Are the batteries or clip bad (corroded, etc.)? If not...
 - [] Check the 1N4148 diode D3 on the CPU board (in the CMOS circuit) If replacing the diode doesn't clear up the problem...
 - [] Check pins 18 and 21 of CMOS-RAM U18. These should be pulsing in Game-Over Mode. If they aren't...
 - [] Use your schematic and check the memory-protect circuit for an open or stuck logic state at chips U43 (pin 8 and pin 11), U16 (pin 6), U34 (pin 6), U41 (pin 6): All these pins should be pulsing in the Game-Over Mode. If these check out but you still have the problem...

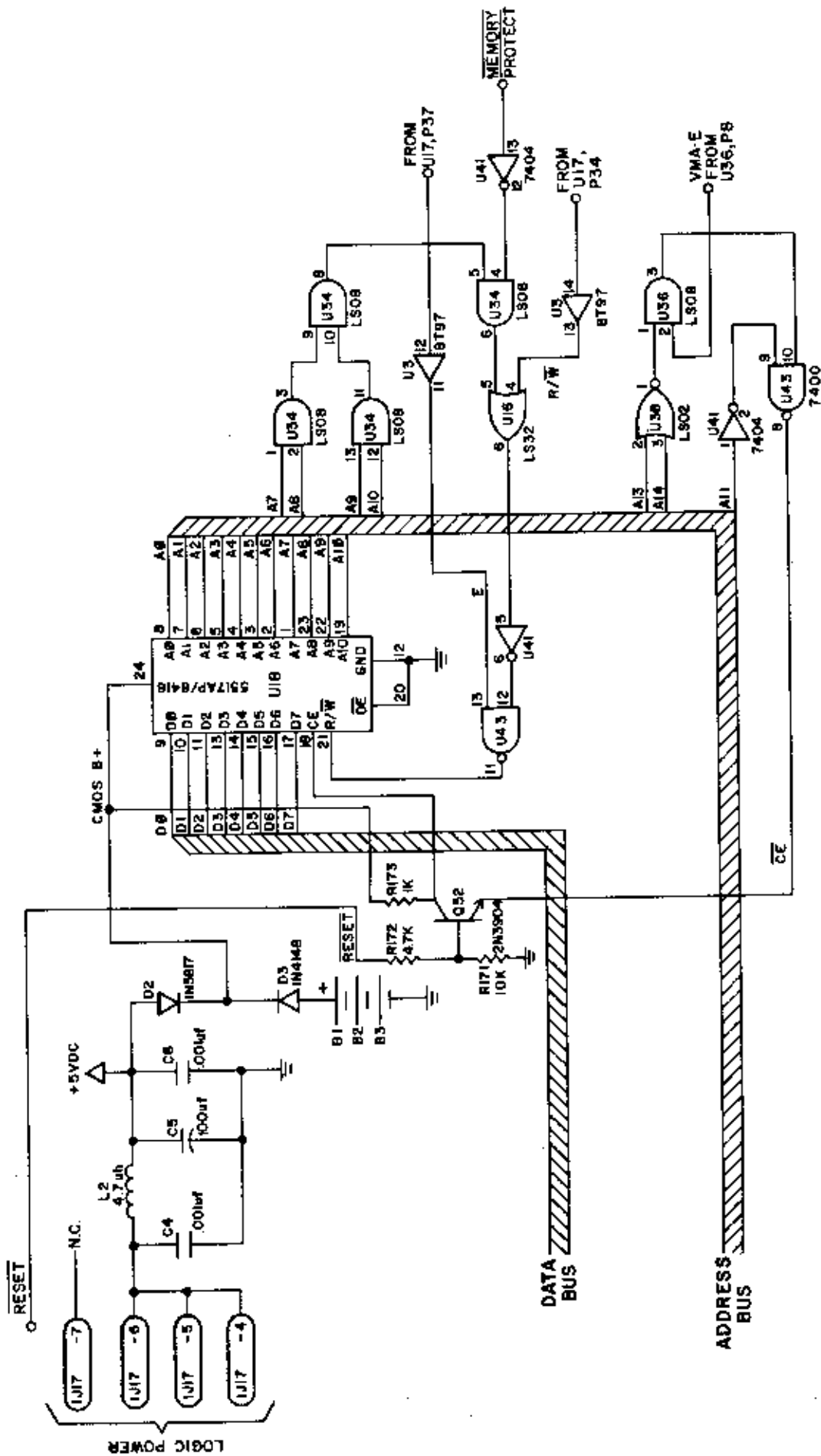

SYMPTOM: MY GAME...

TESTS & PROCEDURES

- [] Check for a shorted 2N3904 transistor Q52: Q52 outputs a 1-second high upon reset or when the game is turned on; the rest of the time it sends a pulse to CMOS-RAM U18's enable pin, #18.

Tilts or gives free credits... [] Check for shorts in the wiring to the credit button or tilt switch.

- [] Check for a wire shorted to ground or to the coin door.

- [] Put the game in the switch test. Check for pulsing at the collectors of the 2N3904 transistors on the CPU board (Q7 through Q14). If the pulsing is absent at the collector of a transistor but present at the base, replace the transistor. These transistors are near connector LJ8. If all transistors are good...

- [] Check the diode on the playfield tilt-switch.

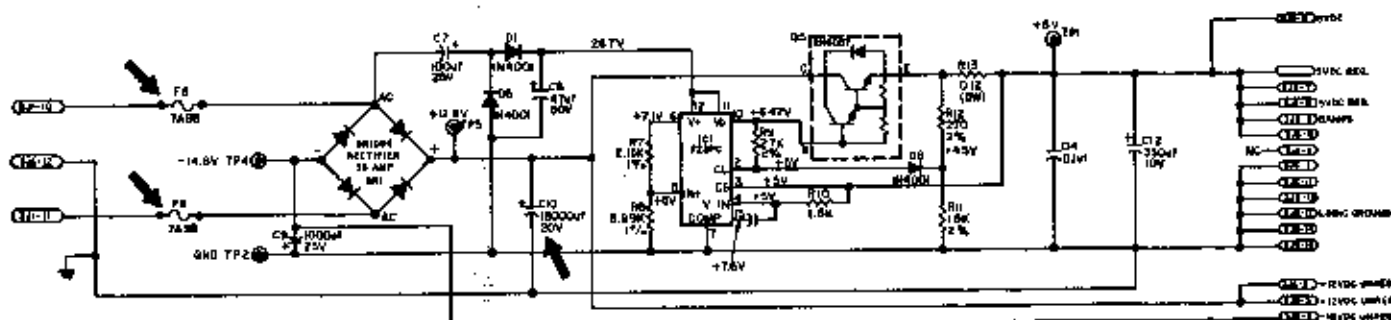

Linear Power Supplies

Crashes or refuses to enter Game-Over Mode

- [] Probable cause: Ripple. Electrolytics dry out after two or three years of operation (rejuvenate or replace bad parts). If the game crashes, check the following...
- [] Is the +5V supply running below 4.75V? Is the +12-unregulated running below 10.7V? (Both voltages should be measured at your CPU board, with all boards connected.) Check or replace capacitor C10 (18,000µF, 20V).

Has weak flippers

- [] Check the +70V supply for correct voltage when flippers are at rest and when they're energized. (It should produce at least +50V when flippers are energized.) If the voltage is low, check or replace capacitor C1 (100µF, 250V) on the flipper power-supply board.

SYMPTOM: MY GAME...

TESTS & PROCEDURES

Flippers

Has one weak flipper

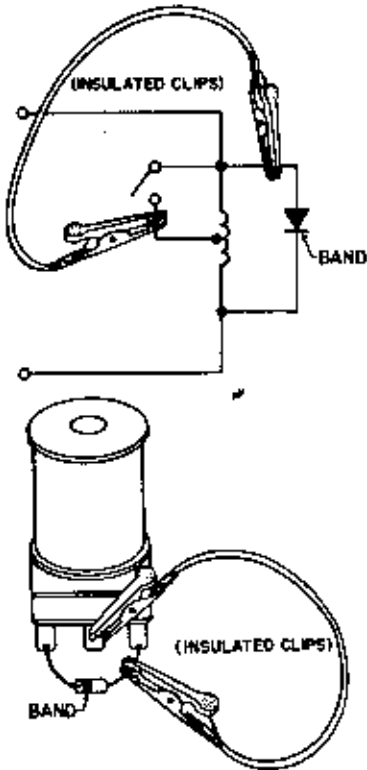

[] Is the diode shorting the flipper coil's center tap to one of the coil's end taps? Or to the flipper frame?

[] Check to see that flippers are at least 1/8" off the playfield; friction can weaken flipper operation and cause playfield wear.

[] End-of-stroke switch (EOS) adjustment may be necessary...

1. Tighten loose brackets and replace broken or worn parts (fiber link, crank arm, etc.)

2. Jump the diode's not-banded end to the coil's center tap. Now momentarily push the flipper button. Does the flipper have full strength? If so, proceed. If not, check the flipper power-supply and review previous steps. To prevent coil damage, remove the jumper.

3. Clean the EOS switch with a file. Gap the switch so that it just opens (about 1/16") when the flipper reaches the top of its stroke. Now your flipper should work like new.

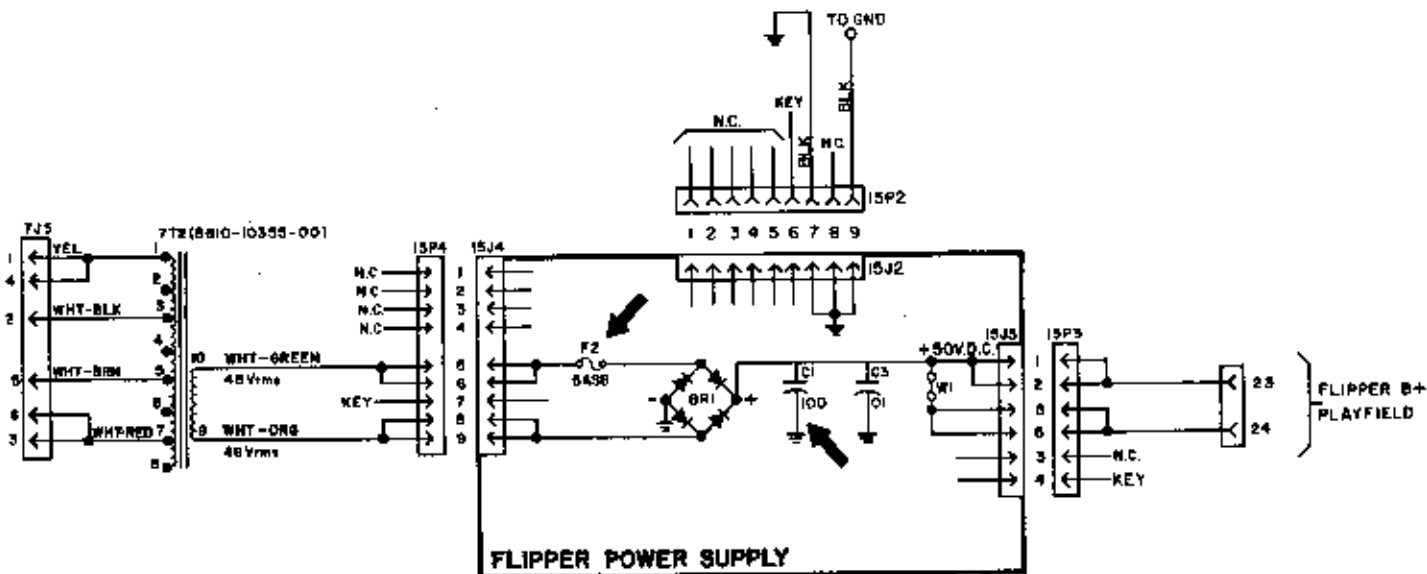

Has dead flippers

[] Turn the game off. With an ohmmeter, check the flipper power board's fuse. If it's open, replace it and retest the flippers. If it's good, proceed...

SYMPTOM: MY GAME...

TESTS & PROCEDURES

[] With the game off, use a 50K, 2W resistor to discharge capacitors in the flipper circuit. Now check the flipper coil for continuity. (Normal readings are 2 to 5 ohms for the pull-in winding and 50 to 80 ohms for the holding winding.) You may have an open coil!

[] Is the diode across the flipper coil shorted? If the coil and diode are good, proceed. If one of the two is bad, replace the bad part and retest performance.

[] Connect one end of a jumper wire to CPU-board connector 1J19, pins 1 or 2. Turn the game on. Touch the other end to the not-banded end of the diode on the flipper coil.

1. If the flipper operates, the problem is in the wiring between the flipper power-board and the flipper (including several connectors and the flipper switch on the cabinet).

2. Use your playfield-solenoid wiring diagram to identify the connectors.

[] Does relay K1 output ground to the flippers during a game, as it should? (The switched-ground output is on CPU-board connector 1J19, pins 1 and 2.) If not, replace the relay.

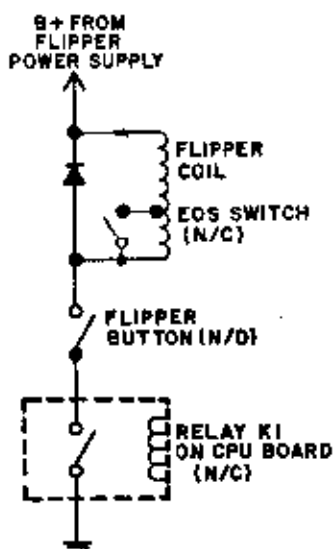

FLIPPER WIRING (CONCEPT)

(N/C = NORMALLY CLOSED, N/O = NORMALLY OPEN)

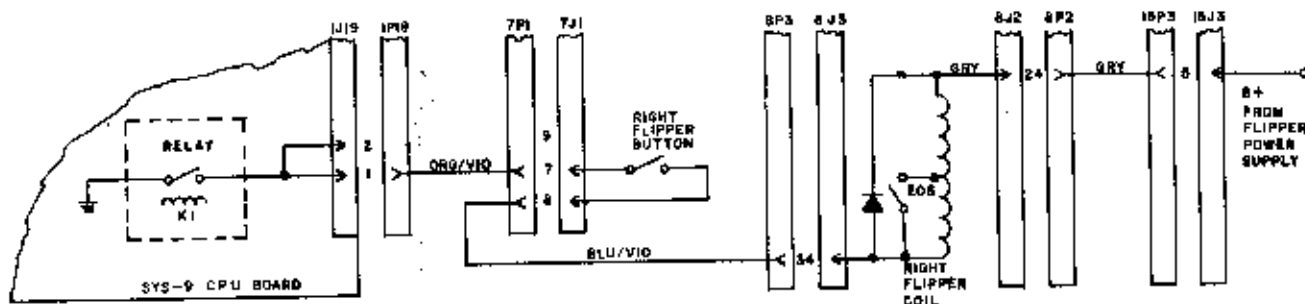

FLIPPER WIRING (ACTUAL)

Switch Problems

Always has rows 1-4 or 5-8 on [] Your game's LANE-CHANGE TM switch may touch a flipper's EOS switch, sending 50-70V to either U51 or U52 (CMOS NAND gates, type 4011).

1. The death of one of these two chips can short either switch rows 1 through 4 or rows 5 through 8, turning them on all the time.

2. Check the flipper assembly for an EOS-to-LANE-CHANGE switch short. Repair it.

KEY (J10-4)

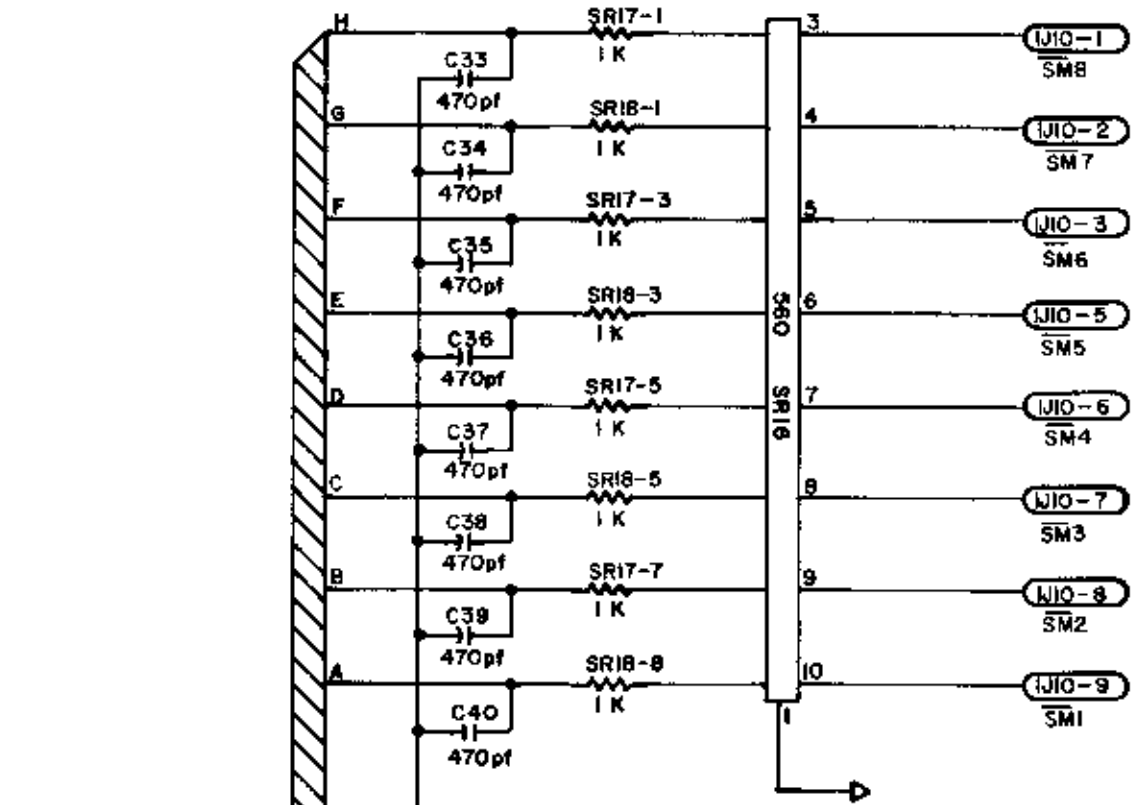

MECHANICAL

SWITCH MATRIX INPUTS

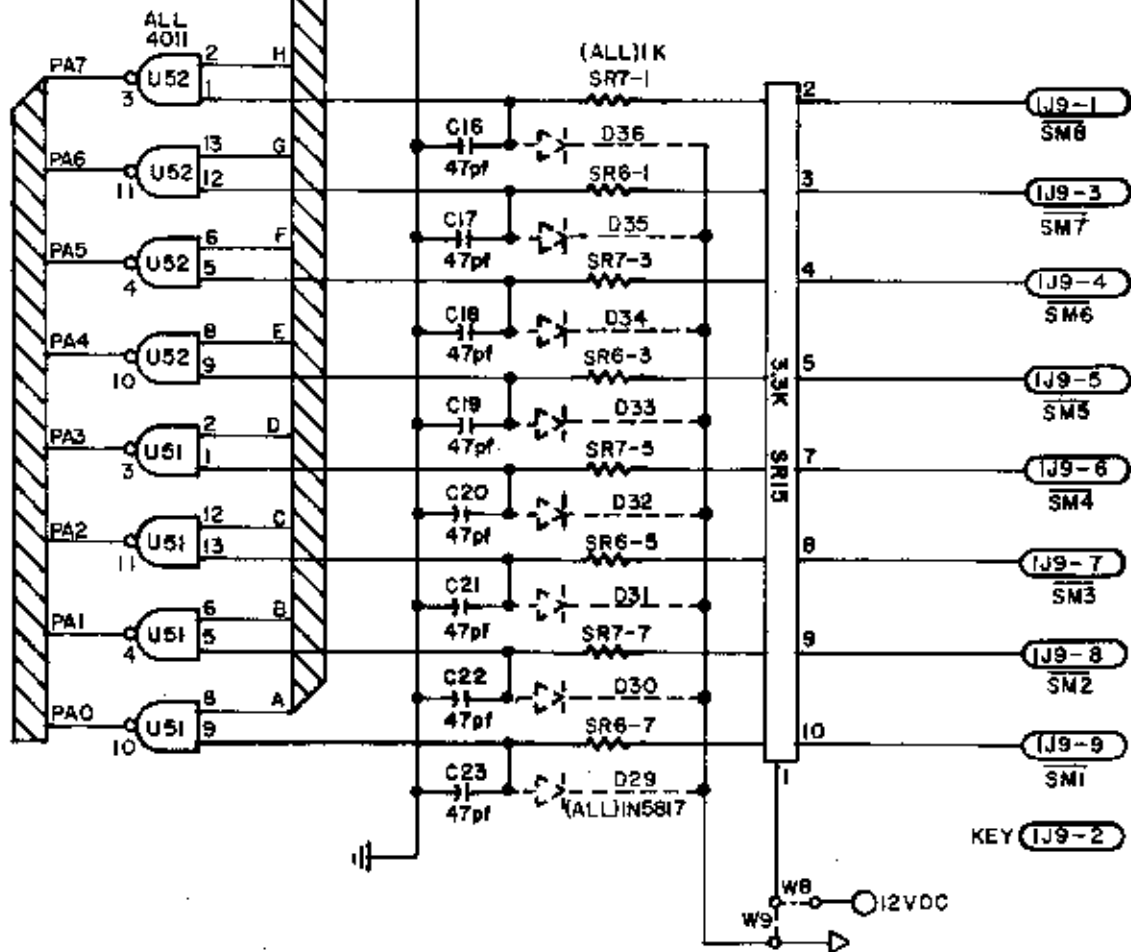

OPTOS

KEY (J9-2)

SYMPTOM: MY GAME...

TESTS & PROCEDURES

3. If rows 1 through 4 don't operate, replace chip U51 on the CPU board. If rows 5 through 8 don't operate, replace chip U52.

Has one switch that causes three others to actuate

[] One of the three has a bad diode.

Has row problems

[] Check the appropriate single-inline package (SIP) pullup-resistors (SR16 or SR15).

Has column problems

[] Check the SIP pullup-resistors (SR8) and the 2N3904 transistors for the stuck rows (Q7 through Q14 on the CPU board).

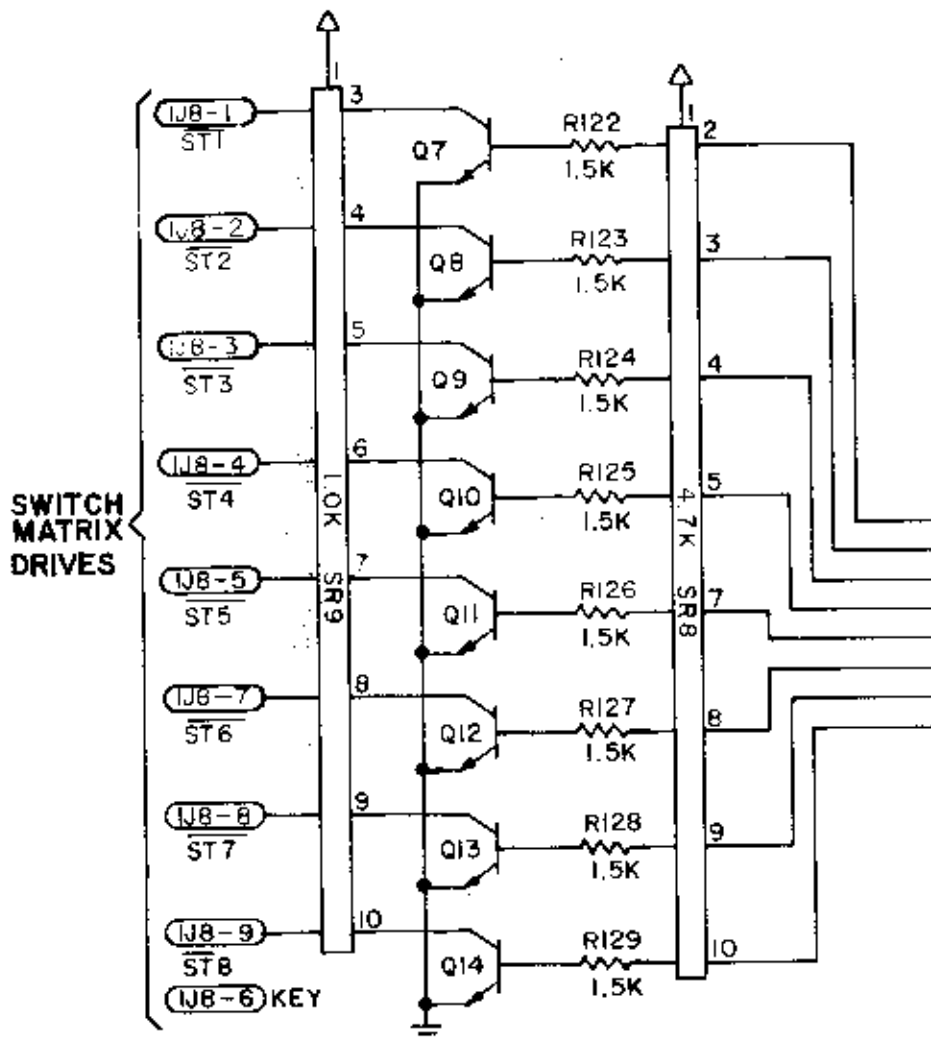

SYMPTOM: MY GAME...

TESTS & PROCEDURES:

Playfield Coils

In general...

- [] Notice that WILLIAMS machines switch ground (instead of B+, like other manufacturers' games)
- [] Special solenoids (jet bumpers, drop targets, kickers, etc.) have two sets of switch points...one for solenoid actuation and a second set for scoring. An RC filter made of a 22uF capacitor and a 100-ohm resistor runs across these points.

Burns up its flipper coils

- [] A bent EOS switch permits the high-energy (pull-in) winding to stay engaged as long as the flipper button is held. Clean the EOS switch with a file and gap it so that it just opens when the flipper reaches the top of its stroke. At this point the EOS gap should be 1/16 inch. Replace the burned-out flipper coil. Now your flipper should work properly.

Burns up its kicker coils

- [] If the kicker rubber is too small, kicker contacts may be forced together. The coil will be constantly energized and will overheat. If the rings are the right size, proceed...
- [] The coil sleeve or some other part of the assembly may be binding. The extra friction will cause the coil to overheat. Look for burrs, heat distortion and worn pieces. Replace the bad parts. For more information, refer to the MECHANICAL SERVICING section.
- [] Sometimes the rubber rings are the right size, but either the switch contacts are bent together or the coil's diode is missing. The consequence is a short in the driver circuit (usually a TIP122 driver transistor or a 2N4401 pre-driver). Check the switch gap and the transistor circuit. Now replace the burned coil.

Pulls in all its coils when I turn it on

- [] The solenoid fuse blows: Check...
 1. the blanking signal (When the game is first turned on, look for a 1-second low, then a constant high at pin 7 of chip U22 on the CPU board). Also check...
 2. chips U59, U6 and U58 in the driver section of the CPU board: The blanking signal should be inverted by these chips (1-second high at pin 6 of U58 when game is first turned on)

GAME-UP/ GAME-OVER LOGIC

GAME-UP: KI "ON", GROUND SUPPLIED TO COILS

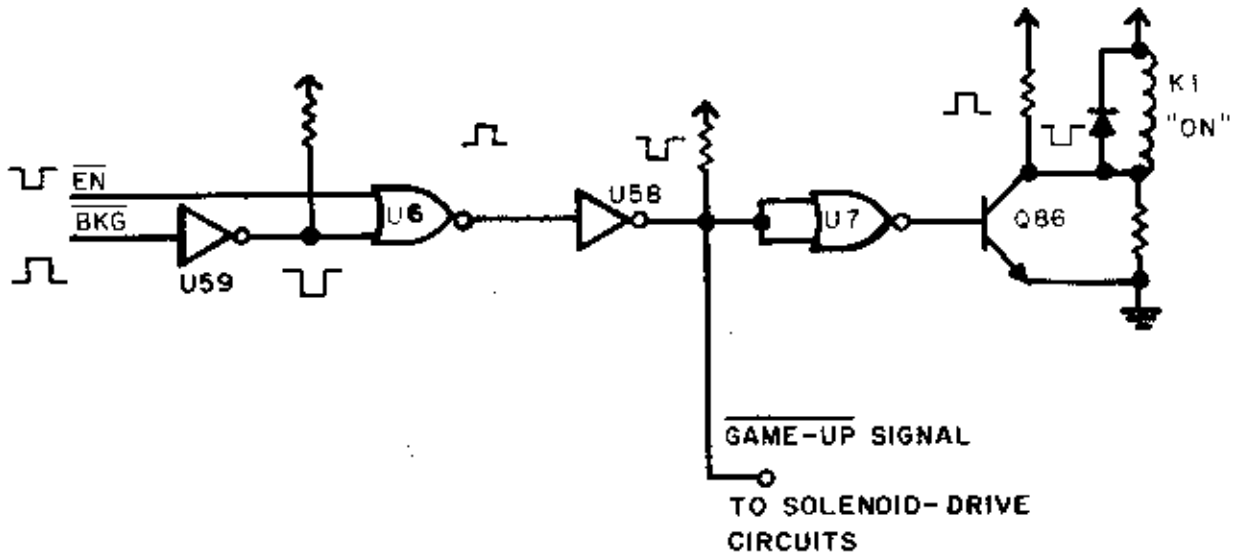

GAME OVER: KI "OFF", NO GROUND SUPPLIED TO COILS

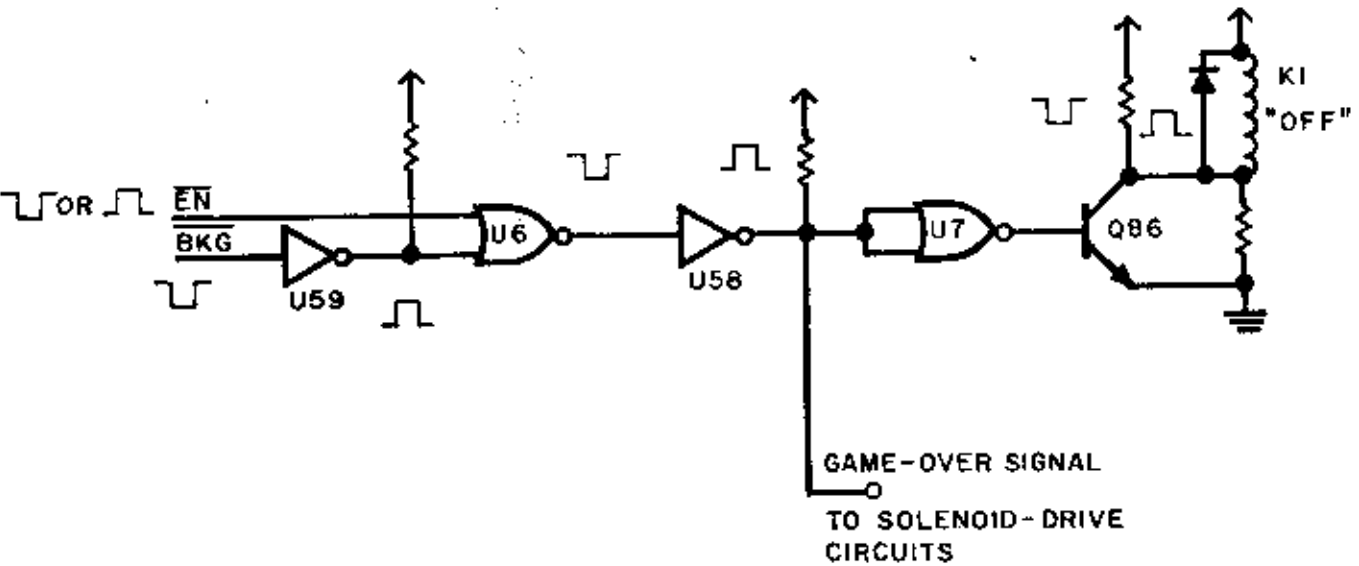

TESTS & PROCEDURES

SYMPTOM: MY GAME...

Pulls in one solenoid when I turn it on

[] IF IT'S A CONTROLLED SOLENOID, CHECK...

1. the coil's TIP122 output-transistor,
2. the solenoid's diode,
3. the 2N4401 pre-drive transistor,
4. the appropriate AND-gate (U56, U57, U60 or U61 on the CPU board).

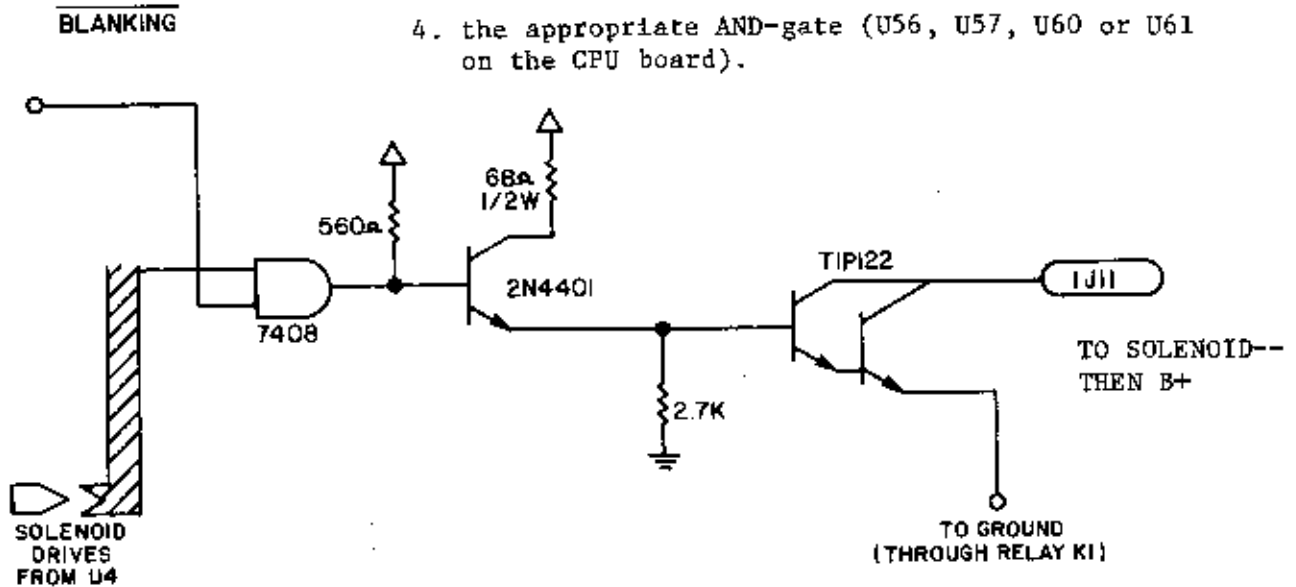

[] IF IT'S A SPECIAL SOLENOID, CHECK...

1. the solenoid's control switch. This switch (on the playfield) may be stuck in the activated position.
2. the 22uF capacitor across the switch.

Has a broken solenoid

[] SWITCH-TRIGGERED (SPECIAL) SOLENOIDS: The solenoid test will help you test controlled solenoids. But to test a switch-triggered solenoid, use Game Mode and pull the solenoid's switch line low. To do this, remove connector

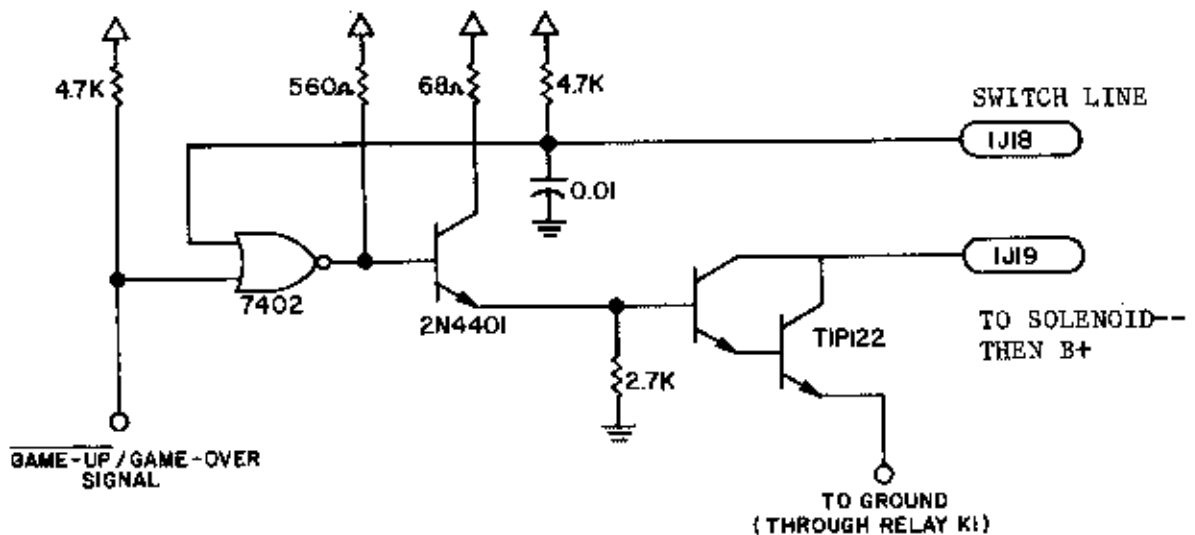

SYMPTOM: MY GAME...

TESTS & PROCEDURES

1J18. Now momentarily ground the solenoid's trigger line at pins 2, 3, 4, 5, 8 or 9. If the solenoid works, the switch may be defective or dirty.

[] ALL SOLENOIDS: Test the wiring...

1. Consult your instruction manual's Solenoid Table. This will give you the number of the dead coil's driver transistor.
2. Use your CPU-board assembly drawing to help you locate this driver transistor.
3. Run a jumper from the tab of the coil's driver transistor (TIP122) to ground. (On these transistors the tab is the collector.)
4. If the coil energizes, the wiring between the transistor and the coil is good. If the coil doesn't energize, proceed...

[] Check the coil for continuity; is it open? Yes? Then replace the coil. No? Then proceed...

[] Is the diode across the coil shorted or open? If shorted, replace the diode. If open, proceed...

[] If the diode across the coil is open, then you'll probably have to replace the coil's TIP122 driver transistor on the CPU board. Also check the rest of the circuit...

1. Use your CPU-board schematic (sheet 1 of 3) to help you understand the driver circuit.
2. Now check the rest of the circuit (7408 AND-gate and 2N4401 transistor for controlled solenoids; 7402 NOR-gate and 2N4401 transistor for switch-triggered solenoids).
3. Use your CPU-board assembly drawing to help you locate the components of the circuit.

Lamps

Has flashlamps that don't work

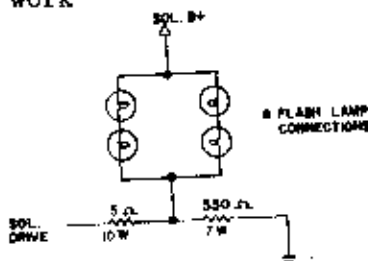

[] #63 or #89 flashlamps are part of the solenoid circuit, not the controlled-lamp circuit. Check the following and replace as necessary...

1. The 330-ohm, 7-watt resistor from each lamp to ground (across the driver transistor);

SYMPTOM: MY GAME...

TESTS & PROCEDURES

- The 5-ohm, 10-watt resistor to the solenoid-driver transistor (TIP122 on the CPU board).

Has controlled lamps that don't work

- [] If one lamp is out, check the #44 bulb, the socket, the 1N4001 diode on the socket and the wiring back to CPU board. If many lamps are out...
- [] Refer to your Lamp-Matrix Table. With the game in Lamp Test, write down the numbers of all the dead lamps. Is an entire row or column of lamps out? If so, proceed...
- [] Use your multimeter or DVM to check the driver transistors in the suspected row or column circuit. Most-often replaced parts are the TIP42 strobe-drivers (column-drivers) at Q23 through 30 and the TIP122 row drivers at Q31 through 38.

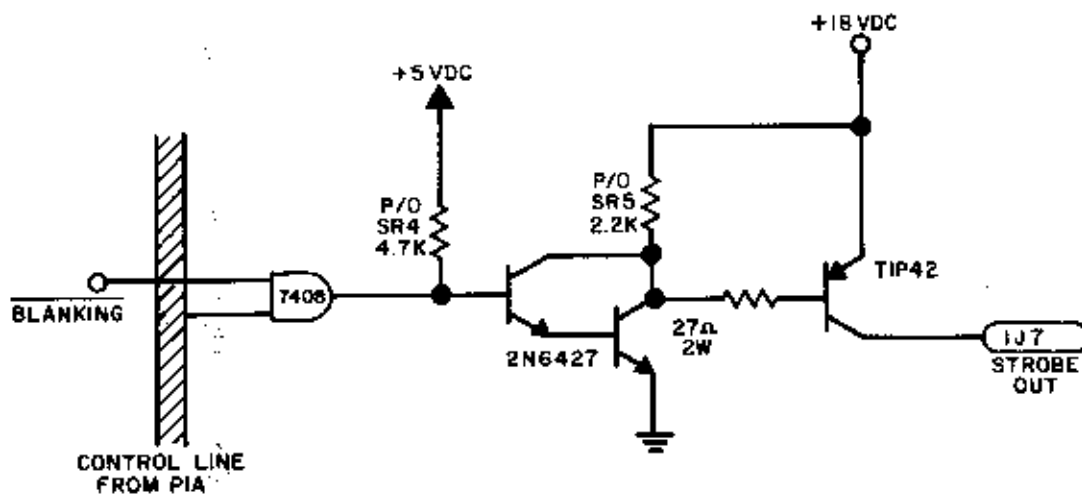

LAMP - COLUMN (STROBE) DRIVERS

- Notice the row and column boxes on the Lamp-Matrix Table. Here we provide the connector numbers for the appropriate column or row circuit shown on the CPU-board schematic (sheet 2 of 3).
- In the Lamp Test, the voltage at the collector tab of a lamp-return (row) transistor should cycle between about 18V and nearly ground.
- The voltage at the tab of a normal lamp-strobe (column) transistor should also cycle. However the pulse amplitude isn't as great as that produced by a lamp-return transistor. (This pulse measures about 0.5Vpp atop 2V of bias.)

SYMPTOM: MY GAME...

TESTS & PROCEDURES

4. When you suspect a row failure, also check the 2N5060 SCR and 1N4001 diode in the CPU-board row circuit. Your manual will assist you...
5. Use your CPU-board schematic (sheet 2 of 3) to help you understand the driver circuit.
6. Use your CPU-board assembly drawing to help you locate the components of the circuit.

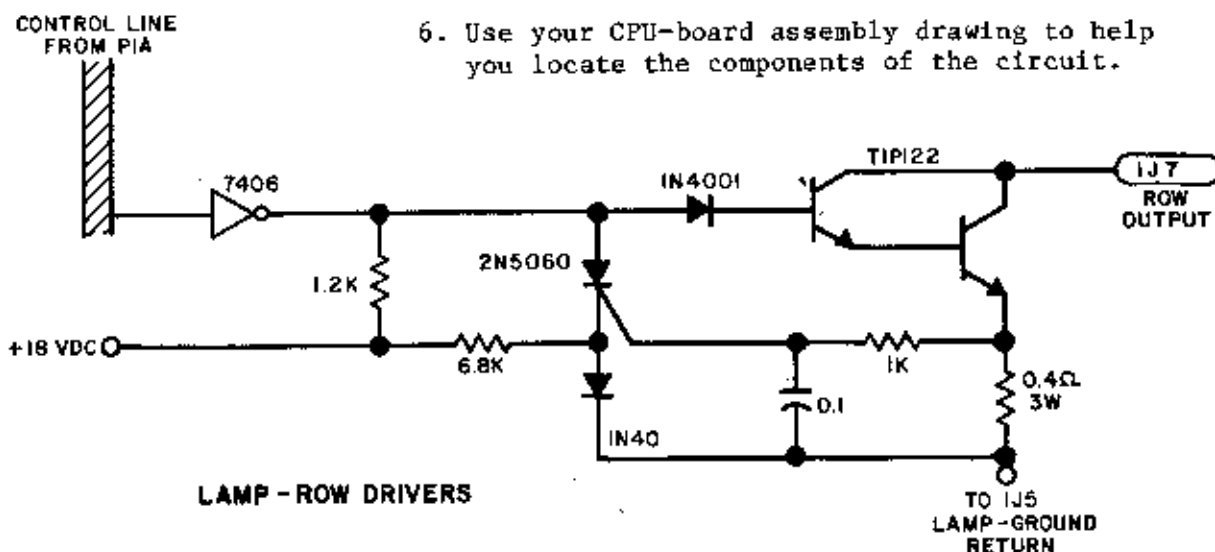

LAMP-ROW DRIVERS

-
- | | |
|------------------------|---|
| Has a lamp-row failure | <input type="checkbox"/> After completing the above tests, find the row circuit and check the 0.4-ohm, 3-watt emitter resistor. |
|------------------------|---|
-
- | | |
|---------------------------|---|
| Has a lamp-column failure | <input type="checkbox"/> After completing the above tests, check the 27-ohm, 5-watt base-drive resistor. |
| | <input type="checkbox"/> If you have a missing column or row, check the appropriate transistor for that column or row. |
| | <input type="checkbox"/> Use your lamp-matrix chart and your CPU-board drawing (sheet 2 of 3) to identify the transistor for the open (always off) or shorted (always on) column. |
-
- | | |
|--|--|
| Has general-illumination lamps that don't work | <input type="checkbox"/> #44 general-illumination lamps are part of an AC circuit that's separate from the controlled-lamp circuit (Controlled lamps are operated with pulsed DC). In some games the general illumination lamps are flashed by the microprocessor via lamp-relay K-1. The following tests are appropriate... |
| | <input type="checkbox"/> Check the jumper wire between connector 3J9, pin 2 and connector 3J8 on the Power-Supply board. |
| | <input type="checkbox"/> Check the fuses on 4-fuse block. |

SYMPTOM: MY GAME...

TESTS & PROCEDURES

- [] Check plugs and jacks 3P8/J8, 8P8/J8, 7P1/J1 and 9P1/J1. Replace worn or melted connectors. And suspect the integrity of the lamp sockets connected to the bad connectors!
- 1. The commonest short is when coin-chute lamps pick up a ground from the metal coin door. If you frequently find a blown 5ASB fuse connected to the white-yellow wire and 7P1/J1, then the short is in the coin-door lamp circuit. Of course this short may be intermittent and it may not occur until you bang on the coin door!
- [] Check power-supply relay K-1 (if used). If it's not used in your game, jump the relay's switch contacts and see if the lamps come on.
- [] If K-1 is OK (or if jumping it doesn't bring back the lights)...test Q56 on the CPU board. Also check the wiring to Q56.

Has no general illumination and no controlled lamps

- [] Check your power supply.

Displays

In general...

- [] The figure on the facing page models the gas-discharge display circuit. In this figure integrated circuits appear as multi-position switches. For simplicity, the microprocessor's means of addressing displays is left out.
- [] Displays have multiple anodes and cathodes. Each anode is a digit. Each cathode is a segment of a digit.
 1. Each anode determines where the displayed number appears.
 2. Each display has seven cathodes. Together they determine what number is displayed.
- [] Display activity requires voltage difference. This difference must appear across any anode/cathode pair in the same tube. We produce this difference by making the cathode much more negative than the anode.
- [] Let's turn on a zero in the 1,000,000 digit of display 1. First we set IC13 to the "1M" position. Next we switch IC1 repeatedly between the "A" through "F" segments.

DISPLAY-TUBE THEORY

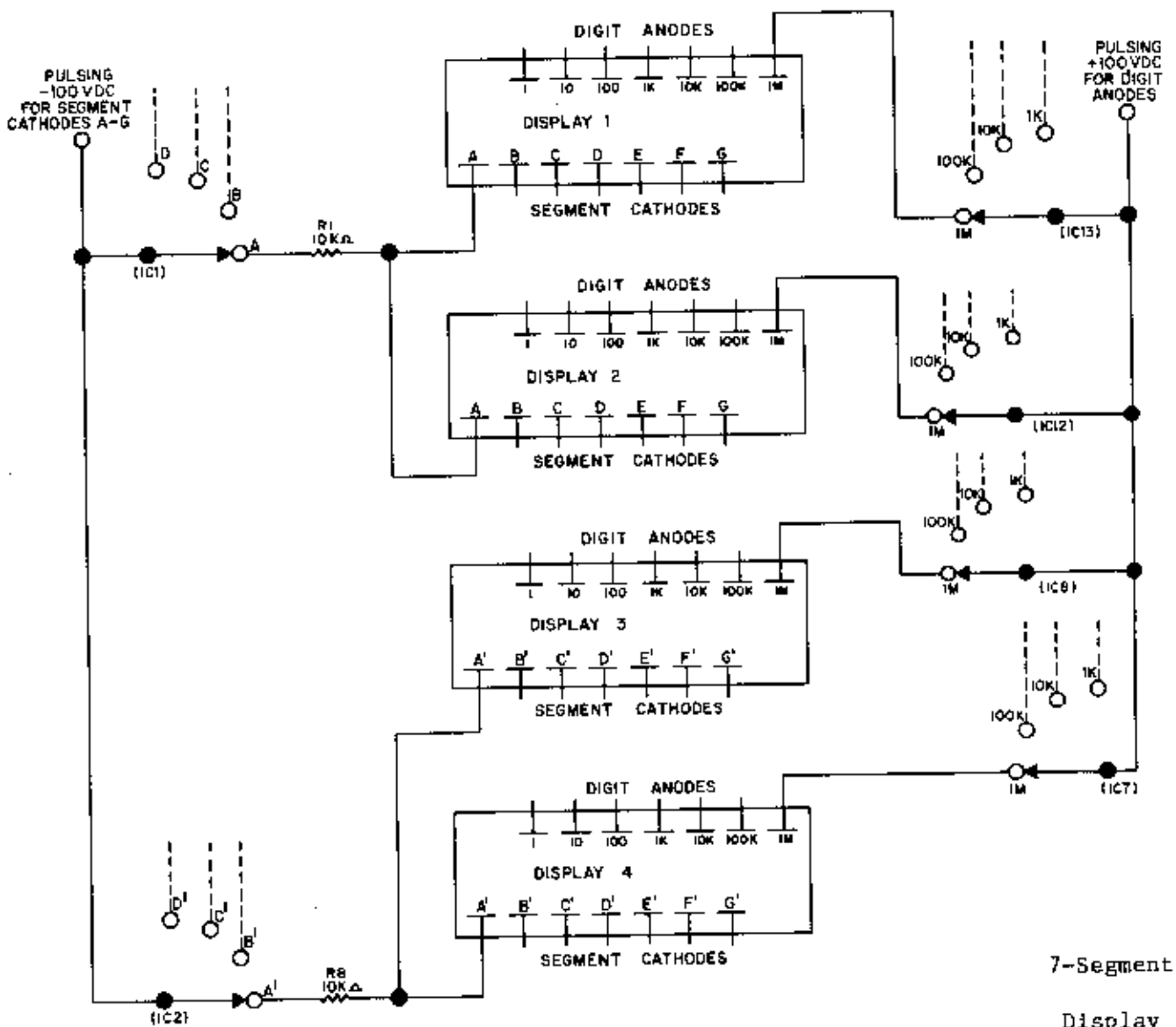

7-Segment
Display

NOTES:

1. 1M=1,000,000
2. K=1,000
3. KEEP-ALIVE ANODES & CATHODES NOT SHOWN
4. COMMA CATHODES NOT SHOWN
5. CREDIT / MATCH CIRCUIT NOT SHOWN

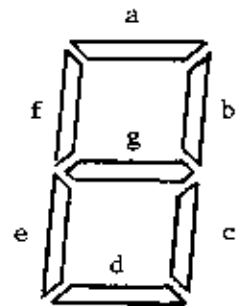

SYMPTOM: MY GAME...

TESTS & PROCEDURES

1. Only display 1's anode and cathode have a difference voltage across them. That's why only display 1's "1M" digit will indicate zero.

Has missing segments or digits on one slave

- Swap the suspected slave unit with a good one

 1. If the segments or digits now light, replace the suspected unit.

Is missing the same segment on two displays

- Find the master-display board. Check segment drivers and burned resistors at the outputs of the appropriate driver-IC. (IC1 for displays 1 and 2 or IC2 for displays 3 and 4).

 1. Check for corrosion on the master-display tube's pins. It uses BOTH segment-driver chips, and could take out BOTH!
 2. Replace the tube or clean off corrosion with a mild abrasive like an eraser.
 3. Repeat the procedure with the remaining tubes in the ailing circuit. Refer to your master-display board schematic.

- Check for an open connection between the CPU board (at connector 1J3) and the master-display board (at connector 4J7).

Is missing the same digit on two displays

- DEFECTIVE STROBE LINE: During the display test, check CPU-board output connectors 1J1 and 1J2 for pulsing. If any pin fails to pulse...
 1. Check SIP resistor packs SR11 and SR12 (all resistors measure 4.7K to Vcc with the game off).
 2. With the game in its display test, check U9 on the CPU board for pulsing on pins 0 through 15.
- DEFECTIVE WIRING: Check the wiring between the CPU board (at connector 1J1 and 1J2) and the master display board (at connector 4J5).
- DEFECTIVE MASTER-DISPLAY INVERTER: With the game in its display test, check the master-display strobe circuit. First, look for pulsing at the outputs of inverter chips 9, 10 and 11.
- DEFECTIVE DRIVER, WIRING OR SLAVE: Now use a DVM to test the high-voltage side of the digit-driver chips, IC's 7, 8, 12 and 13. In display test these outputs should have 90Vpp square pulses on

SYMPTOM: MY GAME...

TESTS & PROCEDURES

them. Your meter averages these pulses to produce a nominal 20VDC reading.

1. A zero reading means a bad chip or a broken trace between the TTL input of the chip and the output of inverter chip 9, 10 and 11.

2. A 20VDC reading means an open connection after the chip's output, or defective slave displays. Check suspected slaves by swapping them with good boards. If the new slaves work, the old ones are defective.

Has displays that "strobe"

[] Ripple causes this symptom. Replace C1 and C3 (100 uF, 150V) on the power-supply board.

1. A shorted series-pass transistor (Q1 or Q3) may also cause this symptom.

Always has blank displays

[] With the game in Display Test (Use MANUAL-DOWN and press ADVANCE once), measure the +100 and -100VDC outputs on the power-supply board.

1. You should read +102.4VDC at connector 3J5, pin 4. AC at this point should only be a few millivolts. (Ground is nearby at 3J5, pin 1.)

2. You should read -102.4VDC at connector 3J5, pin 3. AC at this point should only be a few millivolts. (Ground is nearby at 3J5, pin 1.)

3. If you find 0V at both the +100V and -100V terminals, use your ohmmeter to check the 1/4A fuse at F1. If you find 0V at either the +100V or -100V terminals...

4. You might have an open diode (D3 or D4, type 1N4004) or an open error-amplifier transistor (Q2, MPSD52 for the +100V supply; Q3, MPSD02 for the -100V supply). Also check...

5. The defective circuit's two zener diodes. If either shorts (most likely failure mode), your regulated output voltage will drop near zero.

6. A less likely cause of blank displays is an open series-pass transistor (Q1, SDS201 for the +100V supply; Q3, SDS202 for the -100V supply).

Always blows 1/4A fuse F1

[] You may have a bad electrolytic. If the leaky one isn't obvious (drippy, blistered, etc.), replace the blown fuse and both capacitor C1 and C3. (Each cap is 100uF at 150V). Unless a short

SYMPTOM: MY GAME...

TESTS & PROCEDURES

outside the power-supply board is blowing your fuse, you've probably located your culprit. (If one of the capacitors is still good it will soon fail. You've saved yourself a service call!)

Dumps +118V on the +100V line (or -118V on the -100V line) There's probably a lot of AC ripple there too! Your series-pass transistor is shorted. If you see +118V at 3J5, pin 4, replace transistor Q1 (SDS201). If you see -118V at 3J5, pin 3, replace transistor Q2 (SDS202).

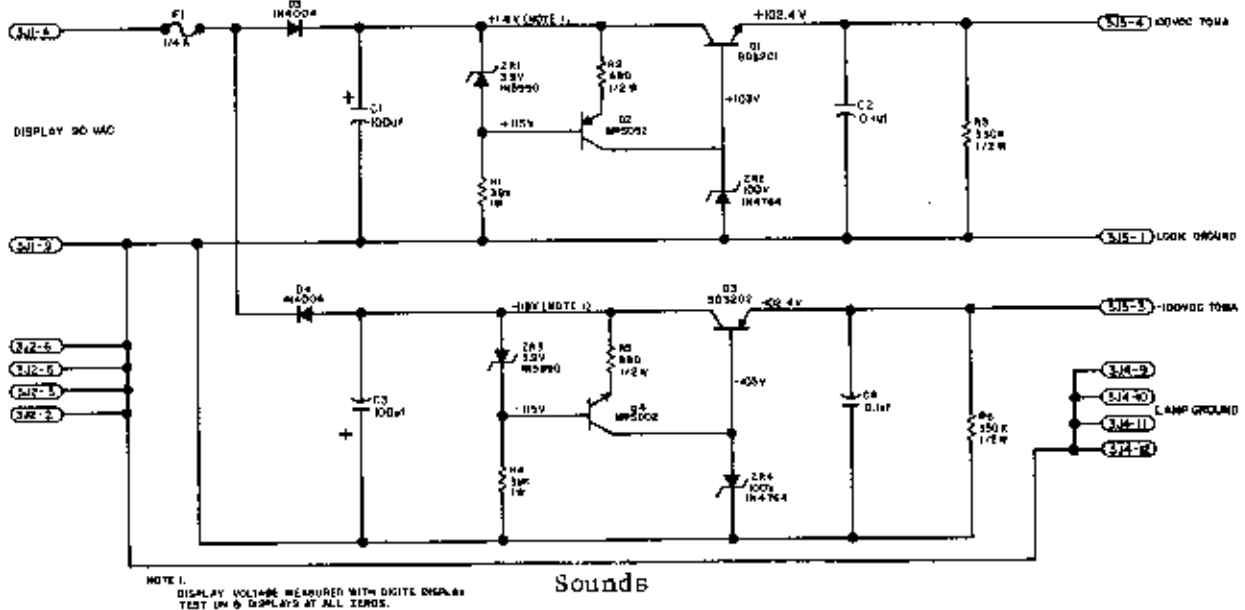

Seems to have a sound problem Press the DIAGNOSTIC BUTTON SW2 on the CPU board. Several electronic sounds should be produced. This Sound Section Test is repeated until the game is turned OFF and back ON.

Has no sound in DIAGNOSTIC TEST (but sounds are present in the Self Test) Check the sound-select inputs (pins 2 through 9 of U13) to see if they pulse during Test 00.

Never has any sound Check the -12V supply voltage on the CPU board. If this voltage is low (or AC ripple seems too high)...
 1. Check the gray and gray-green transformer-secondary wires for 18.7VAC;
 2. In the -12V supply, check the filter-capacitor (C7 on the CPU board) for excessive AC (over 0.75 VAC).

Still has no sound Turn the volume control all the way up. With the game turned on, momentarily place a cold but powered-up AC soldering-pencil on the bottom side (U59 side) of capacitor C29. DO NOT use a

SYMPTOM: MY GAME...

TESTS & PROCEDURES

soldering iron of over 40 watts. Cordless models do NOT work for this test.

1. If you hear a low hum, the power-amplifier chip (TDA2002 on a vertical heatsink) and speaker are okay. Your volume control or its wiring may be bad.
2. If you don't hear a low hum: Individually check (in order of possible failure) the power-amplifier chip (TDA2002), speaker, speaker wiring and capacitor C24. Do this by substitution, one part at a time. A test speaker on short jumper cables will help you perform your speaker and wiring tests.

[] OTHER AREAS TO CHECK...

1. Is there pulsing on the data lines of microprocessor U11 (pins 26 through 33)? If not, swap the microprocessor, then the other socketed chips (RAM U12, ROM U49).
2. If there's no pulsing anywhere in the sound section, check the 4MHz line from U17.
3. Is there pulsing on the data and address lines of PIA U13? If not, check power-pin 20 before replacing the chip.
4. Capacitor C31, transistor Q51 and digital-to-analog converter U48 rarely fail.

Power, Bus and Clock Problems

Won't enter Game-Over Mode; numbers 0, 1 or 7 are stuck on my CPU-board indicator (locked-up or stalled game)

- [] Try the Memory-Chip Test: Press the CPU-board DIAGNOSTIC button. If you see a 2 or 3 on the CPU-board display, replace chip U20. If you see a 4 or 5, replace chip U19. (Both chips are on the CPU board.) If the machine's still locked up, proceed...
- [] The unregulated 12V line on the CPU board (connector 1P17, pin 9) will cause the reset circuit to malfunction if the voltage there falls below 10.7V.
 1. Since this 12V source is unregulated, check for AC as well as DC, but consider 5% AC (about 0.6V) normal. This voltage must be within 10% of its rated output (12VDC).
- [] Check the +5VDC on CPU board (pin 20 of microprocessor U17). If it's missing, replace fuses F5 and F6 on the power-supply board and

SYSTEM-9 RESET CIRCUIT

| DEVICE | ZR1 | Q1 | Q2 | Q3 | Q4 | Q5 | RESET IN | RESET OUT |
|--------------------------|-----|----|----|----|----|----|----------|-----------|
| PULSE AT DEVICE'S OUTPUT | L | H | L | H | H | L | H | NO RESET |
| | H | L | H | L | L | L | H | RESET |
| | L | H | L | H | L | H | L | RESET |
| | H | L | H | L | L | H | L | RESET |

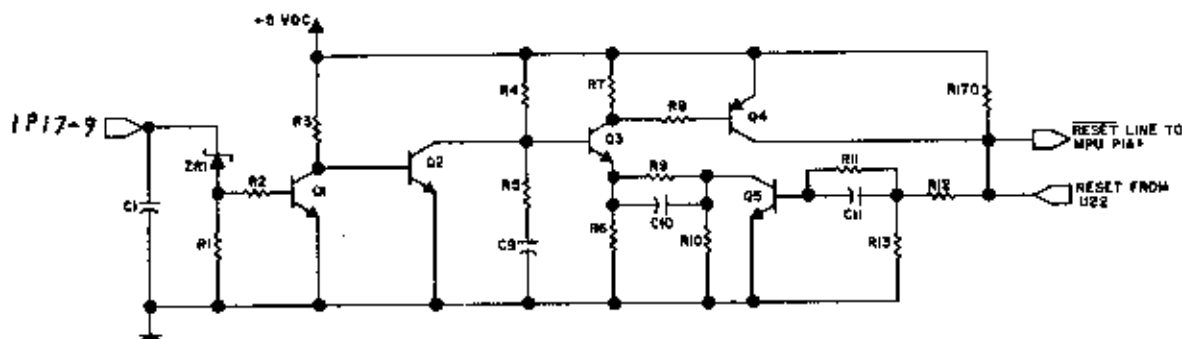

EQUIVALENT LOGIC CIRCUIT (IGNORING RC NETWORKS)



| TRUTH TABLE | | |
|-------------|----------|--------------|
| ZR1* | RESET IN | RESET OUT |
| H | H | H = NO RESET |
| L | H | L = RESET |
| H | L | L = RESET |
| L | L | L = RESET |

*L = LESS THAN 0.8VDC AT +5VDC INPUT

SYMPTOM: MY GAME...

TESTS & PROCEDURES

retest both the +5VDC and unregulated +12VDC on the CPU board.

[] Be sure that your +5VDC supply is within 5% of its rated output (4.75V-5.25V). If it doesn't fall within this tolerance, your machine may suffer further damage. Repair or replace the power supply before proceeding to the next checkbox...

1. Test the +5VDC circuit on the power-supply board. First use the DC setting on your multimeter. Check again using the AC setting. If the voltage at TP3 (hot end of capacitor C10) is less than +11VDC or if you find more than 0.6V of AC ripple, replace C10.
2. IF TP1 IS LESS THAN +4.95VDC, then check precision resistors R7 and R8. If they're outside the 1% tolerance, replace them. If they're within the 1% tolerance then check IC1.

[] There shouldn't be more than 0.005VAC on the CPU board's +5VDC supply (check pin 20 of microprocessor U17). If there is, perform the next checkbox. If there isn't, skip the next checkbox...

[] If there's a lot of AC (a few volts, as well as DC) here, you may have a leaky C10 on the

SYMPTOM: MY GAME...

TESTS & PROCEDURES

power-supply board: replace it! If your game still doesn't enter Game-Over Mode, proceed...

- [] If the game plays, your problem's on the power-supply board. If the game doesn't play, check the power transformer with your voltmeter.

IS STILL LOCKED UP!

- [] Place a logic probe or scope probe on the reset line of the microprocessor (an input at pin 40 of U17); after you turn on the game, this pin should show a one-second low followed by a constant high while the machine is on. If you don't see the pulse, replace the chip. If you do see it, proceed...
- [] In Game-Over Mode check these U17 microprocessor pins for pulsing:
 1. IRQ (interrupt request, pin 4)
 2. crystal (pin 39)
 3. address lines (pins 9 through 25)
 4. data lines (pins 26 through 33)
- [] Check U21 for activity with a logic probe or scope. Also check its solder connections.
- [] As a test, swap U20 (Game-ROM 1) with a good chip from a working game.
- [] As a test, swap U17 (main microprocessor) with a good chip from a working game (or use U11).
- [] As a test, swap U19 (Game-ROM 2) with a good chip from a working game.
- [] Check to see that ONLY the CPU-Board jumpers specified in your game's instruction manual are present.
- [] If the game's still locked up, use your logic probe to check the chip-enable (CE) pins on the ROM chips. If they aren't pulsing but the main clock (U17, pins 38 and 39) is pulsing, address-decoder chip U24 is probably bad.

Has "7" on its CPU-Board readout

- [] Press sound DIAGNOSTIC button. If you hear a buzz or lots of garbage, you probably have a bad crystal. This is because both the main processor and the sound processor use the same crystal.

SYMPTOM: MY GAME...

TESTS & PROCEDURES

1. If both processors are down, the crystal may be defective or it may be poorly soldered to the CPU board....
 2. We assume here that microprocessor U17 is receiving +5VDC and no more than 0.005VAC at pins 8 and 35. If this is the case, replace crystal U21.
-

Speech Board

Has sounds but not speech

- [] Not all WILLIAMS games are programmed for speech. But if your game was meant to be a talking game there are several areas you should check...
1. If all speech is missing, press the SOUND DIAGNOSTIC button and then adjust the sound/speech mixer pot on the Speech board. If this has no effect, leave the pot turned about halfway and proceed...
 2. With your voltmeter, check for +12VDC at pin 8 of U2 and U3 on the Speech board. Now check for -12VDC at pin 4 of chips U2 and U3. Missing voltages probably mean bad traces or a bad ribbon connector between the Speech and CPU boards.
 3. Press the SOUND DIAGNOSTIC button. Use a sensitive voltmeter or scope probe and check for AC at pin 2 of chip U3 on the speech board. If there's no AC, turn the game off and replace C1. If you have a signal there, proceed.
 4. Press the SOUND DIAGNOSTIC button. Use a sensitive voltmeter or scope probe and check for AC at pin 7 of chip U3 on the speech board. If you have a signal there, proceed. If there's no AC, turn the game off. Using a socket for the new part, replace U3. Now repeat step 5 with the new part.
 5. Press the SOUND DIAGNOSTIC button. Use a sensitive voltmeter or scope probe and check for AC at pin 6 of chip U2 on the speech board. If there's no AC, turn the game off and replace C12. Repeat step 7 with the new part. If you have a signal there, you should have restored speech to the game. Otherwise, proceed...

SYMPTOM: MY GAME...

TESTS & PROCEDURES

6. Using a socket for the new part, replace U2. Now repeat step 7 with the new part. If you still have no sound, adjust the sound/speech mixer pot. Also try swapping the ribbon connector. Other parts of the circuit such as resistors, small-value capacitors and the digital-to-analog converter chip U1 seldom fail.
-

Forgets to say several words

[] If not all the words are missing, consult your manual. It includes a chart of the words your game should produce when the SOUND DIAGNOSTIC button is pressed. This button is on the CPU board.

1. Press the SOUND DIAGNOSTIC button. Now note the missing words and proceed...
2. Use the chart to find the bad ROM chip (U4, U5, U6 or U7 on the Speech board or sometimes U49 on the CPU board).

CHAPTER 4. REFERENCE INFORMATION

Function Finder: A glossary of terms
used by pinball technicians

Pin Functions of 6802 and 6808
Microprocessors

System-9 Control Locations

Replacing System-9 Circuitboards

ROM Summary for a Typical System-9 Game
Connector Code

All About Coil Numbers

An Introduction to Self-Diagnostics

System-9 Games Play on System 11

CPU-Board Jumper Table

Speech-ROM Comparison Table

System 9 to System 11 Conversion Table

Index

Feedback Form

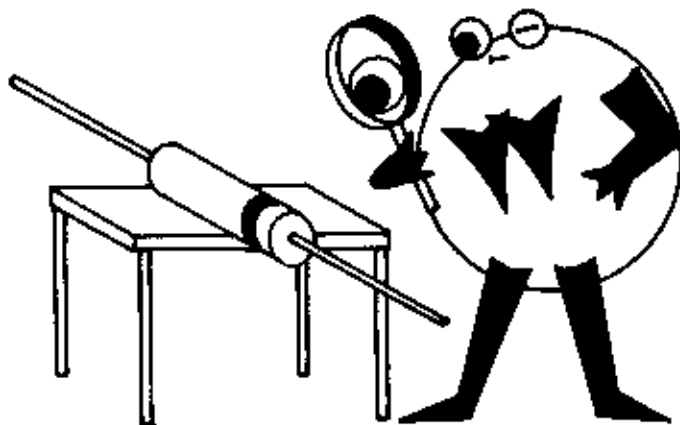

Function Finder

A glossary of electronic terms used by pinball technicians

FUNCTION

DEFINITION

AND GATE

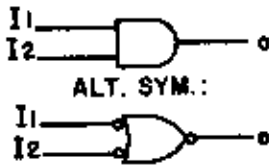

A circuit that produces a high (logic 1 or H) output only when all inputs are high. Other situations produce a low (logic 0 or L) output. Your game's 7408 chips each contain four AND gates.

TRUTH TABLE

| I1 | I2 | O |
|----|----|---|
| H | H | H |
| H | L | L |
| L | H | L |
| L | L | L |

ACTIVE LOW

Refers to circuitry that responds to a logic level of 0 (low). Also, active-low signals produce an effect only when they fall low. A bar over a function-name means it's an active-low signal (for example, \overline{IRQ}).

ANALOG

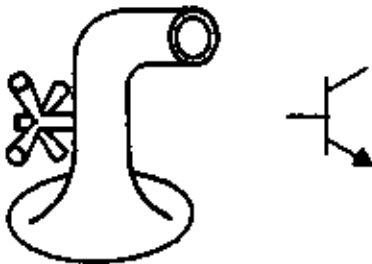

ALSO KNOWN AS LINEAR. The electronics of valves including transducers, tubes, transistors, FET's and other devices. Analog circuits represent information as voltage, current, phase, frequency, etc. that varies in proportion to the input variables. The output waveform must be derived from some characteristic of the input waveform. This requirement is contrary to the situation with digital electronics. Voltage and power amplifiers are common analog circuits used in your game.

2 FAMILIAR

VALVES, ARRANGED SO THAT PARTS OF SAME FUNCTION ARE IN SAME POSITION..

OTHER MEANINGS...Sometimes the term ANALOG refers to a switching circuit that operates at some other voltage besides +5VDC. Also technicians may call switching circuits (especially peripherals) analog if they're built with discrete parts. One example is a solenoid driver from your pinball machine. Moreover, so-called "analog switch" chips pass analog as well as digital waveforms.

BA

BUS AVAILABLE. Some MC6802/6808 systems require a signal when the address bus is available to chips other than the microprocessor (MPU). In these systems, BA must be high before another chip can access the bus. However in our system BA isn't connected.

BACKGROUND PROGRAM

This program, stored in your game's firmware, is common to all system-9 games. It includes your machine's operating system, its diagnostic subroutines, most of Bookkeeping Mode, and about half of your game's adjustable features. You'll find the term background referred to in your manual's Game-Adjustment Table.

BETA

A transistor's current gain in a common-emitter circuit (the ratio of output current to input or control current): Also called Hfe. This is one of the specifications you must consider when replacing transistors. The others are...

- *sex (PNP or NPN)
- *PD (maximum power dissipation)
- *Ic (maximum output current)
- *BVCEO (collector-to-emitter breakdown voltage)
- *fT (highest output frequency)
- *safe-operating curve
- *package type (will the replacement fit the heatsink?)

BIAS

ALSO CALLED OFFSET. A DC voltage that sets where a transistor's output will be zero. You can bias a transistor so that it faithfully reproduces an input for analog circuitry. Or you can bias a transistor so it's always either saturated (low) or cut off (high). In that case you've produced an electronic switch useful for digital circuits.

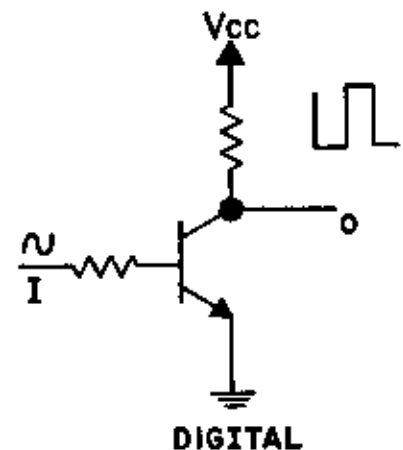
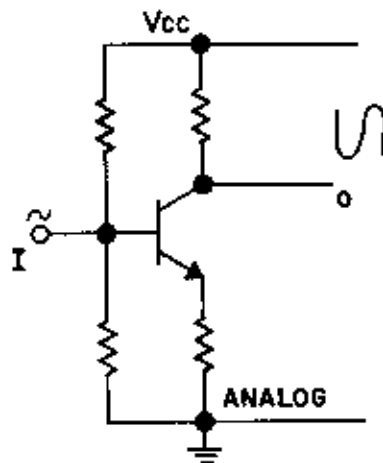

BINARY

A system of information coding that involves combinations of high and low values such as one and zero, yes and no, etc.

BIT

The smallest piece of information resolved by digital circuits including computers. A bit represents a binary digit, either a one or a zero.

BUFFER

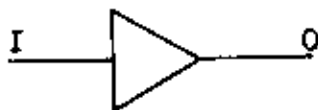

ALSO CALLED YES GATE...A circuit that increases the fan-out of a digital IC. Buffers also serve to isolate chips from one another and from the bus system. Buffers are equivalent to amplifiers in analog electronics: In fact, discrete transistors may be used as buffers (Depending on circuitry, a transistor may or may not invert a pulse). Your game's 8T97 hex, tristate chip contains six buffers.

TRUTH TABLE

| I | O |
|---|---|
| H | H |
| L | L |

BUS

Most computers (including your pinball computer) have lines connecting the microprocessor to external memory chips and peripherals. These lines are called busses. Each bus consists of several wires: There are three types of bus in your computer: (1) The address bus permits the microprocessor to identify a memory location. (2) The two-way data bus carries information between the MPU and external memory or peripherals. (3) The MPU uses its control bus to enable only the chip it wishes to address.

BLANKING

A normally-high signal that's low during power-up and comes high (+5VDC) after reset. Blanking prevents the system from locking lamps and solenoids on at power-up.

BYTE

To a computer, a byte is a word. Bytes are eight bits long.

CA1

CONTROL-A ONE. An MC6820 or 6821 PIA has two interrupt inputs. This is one of them:

CA2

CONTROL-A TWO. One of two peripheral-control lines on an MC6820 or 6821 PIA. This line can be set up as a PIA-interrupt input or a peripheral-control output.

CB1

CONTROL-B ONE. One of two interrupt inputs on an MC6820 or 6821 PIA.

CB2

CONTROL-B TWO. One of two peripheral-control lines on an MC6820 or 6821 PIA. This line can be set up as a PIA-interrupt input or a peripheral-control output.

CE1

CHIP-ENABLE ONE-NOT. An input to many ICs. When low, it allows the IC to operate.

CLOCK

Also known as: System clock, crystal clock, clock generator. The means of timing or synchronization for system operations. Your pinball computer (and most modern computers) include an electronic oscillator. Controlled by a piezoelectric crystal, your game's oscillator generates very precise, 4 MHz square waves. The microprocessor divides this frequency to produce E-clock signals.

CMOS RAM

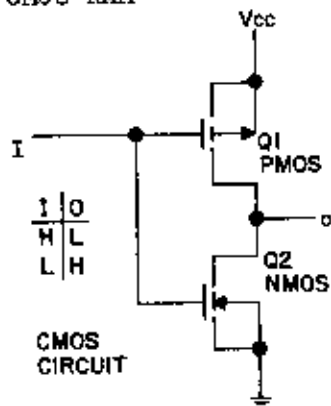

COMPLEMENTARY, METAL-OXIDE SEMICONDUCTOR, RANDOM-ACCESS MEMORY. What a mouthful! This jargon describes a read-write memory incorporating one type of field-effect transistor (the MOSFET). The complementary aspect refers to CMOS circuits' use of both MOSFET sexes, PMOS and NMOS devices.

WIDE VOLTAGE RANGE: MOSFETs distinguish themselves by being voltage-controlled devices...which boils down to the fact that they require very little power. Moreover they can be operated at a wide range of supply voltages (unlike standard TTL circuits).

BATTERY OPERATION. These are the perfect specifications for an IC that must operate off a steadily falling battery voltage, as does your CMOS RAM. The 5517AP CMOS RAM in your game is the static type. It stores bookkeeping totals, game adjustments and other data for your pinball computer.

CMOS RAM B+

This indicates the battery supply for the CMOS RAM: Your CMOS-RAM B+ voltage should measure at least +3.8V with no power applied to the CPU board.

COUNTER

ALSO KNOWN AS DIVIDER: This circuit produces an output pulse after it receives a certain number of input pulses. Counters are built with J-K flip-flops and other small gates. Each flip-flop divides the frequency of the incoming pulse train by two. Your game uses a 4020 CMOS counter in the PIA interrupt-control circuit:

CS0, CS1, $\overline{CS2}$

CHIP SELECT 0, 1, 2. These are PIA inputs the MPU uses to address a PIA. With CS0 and CS1 high and $\overline{CS2}$ low, the PIA is selected.

DAC

DIGITAL-TO-ANALOG CONVERTER: Also called D/A converter. This circuit translates the binary information of digital circuitry into an analog waveform that can be amplified. Your game uses an MCI408 DAC in its sound section.

DARLINGTON

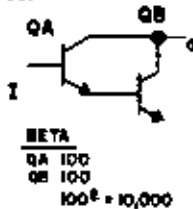

A transistor circuit noted for extremely high current gain (beta may range between 500 and 25,000). This two-transistor circuit is used to drive solenoids in your pinball game. The darlington circuit is so useful as a power amplifier that it can be purchased in a single package (like the TIP122 power transistor used in your solenoid circuit):

DECODER

Decoders translate information from one counting system to another (eg., BCD to hexadecimal). Information enters the decoder on a few lines and exits on several lines. Your game computer uses a 74LS139 (dual 2-to-4 line) decoder to select Game-ROM 1 or Game-ROM 2.

DIGITAL

The electronics of switching devices including discrete switches, relays, tubes, transistors, FET's and other devices. Digital circuits represent data as bits or digits. That is, logic gates produce a high (1) or low (0) output when they receive a high or low input. Output waveforms need not be derived from characteristics of input waveforms (as in analog electronics).

DIP



DUAL-INLINE PACKAGE. This term defines the buglike shape of many integrated circuits (Most of the IC's in your game are the DIP type). Such devices are rectangular, with legs in two parallel rows. One row of legs runs down each side of the rectangle. DIP switches and DIP resistors are also common:

PIN NUMBERS ON DIP DEVICES...Commonly pins are numbered in a counterclockwise direction (as the chip is viewed from the top): Pin numbering begins with the pin nearest a white circle embossed into the package. Alternately, there may be a notch in one side of the chip. When the notch points north, the top pin on the west is number one. If a chip has no dot or notch, the first pin is usually determined by the print on the chip. When the print points north, the top pin on the west is number one.

- DISCRETE One transistor per package (as opposed to an integrated circuit, which has numerous transistors in one package).
- DISPLAY Any means of reproducing information in readable form.
- DYNAMIC RAM ALSO DRAM. This type of random-access memory needs to be refreshed or it loses its data, even when it's under power.
- E ENABLE. This is the system clock (an MPU output) that runs at 1 MHz.
- EOS SWITCH END OF STROKE SWITCH. (Also called EOS) Your flipper coils have two windings. The EOS switch selects both of them (for lift) or only the high-resistance winding (to keep the flipper up).
- YOUR EOS SWITCH is mounted on your game's flipper assembly. When the flipper is resting or rising, the EOS remains closed. This allows the flipper full power, because both its high-resistance winding and its high-current winding energize when you press the flipper button.
- However when the flipper reaches the top of its arc (end of its stroke), a pawl (bump) on the assembly forces the EOS switch to open. This action disengages the high-current winding: Now the flipper may remain up for some time without overheating.
- If the EOS switch is badly adjusted, the high-current winding may stay engaged. This winding is meant for intermittent duty. If energized for extended periods, the high-current winding eventually burns out.
- EPROM ERASABLE, PROGRAMMABLE, READ-ONLY MEMORY. This is the type of permanent memory used to store the operating system and game programs for your pinball machine. Since the game's operation depends on this information, the MPU can't write over it: These chips are only erasable and programmable in the sense that the factory can alter them. When you replace these EPROMs, remember that only a programmed chip will permit your game to operate. As a general rule, EPROMs from different games aren't interchangeable.
- EXTAL CRYSTAL CLOCK. This MPU input is used with external 4MHz clocks (such as the one in our system). The MPU divides the 4 MHz down to 1 MHz for system operation: The E clock results.
- FAN-OUT The current-driving capacity of a chip: Fan-out is expressed in terms of how many standard TTL units a chip can drive before it exceeds parameters or ceases to provide useable logic levels.
- FLIP-FLOP The simplest digital memory, a flip-flop can hold one bit of information. This circuit has two stable states, and can be caused to switch between them. Your game uses a 74LS374 D-type flip-flop for precisely this purpose. Versatile circuits, flip-flops are the basis for registers,

RAMs, decade counters, the frequency dividers inside clock circuits and more...

FOREGROUND PROGRAM

This part of your machine's software gives your game its unique personality. In general, this series of routines usually includes bookkeeping features above function 12 and game adjustments above function 30 (except for functions 40, 41 and 50, which are background functions).

GAS-DISCHARGE DISPLAY

A tube containing neon or another noble gas at a very low pressure. When the anode is substantially more positive than the cathode, a glow (ionized gas) develops near the cathode.

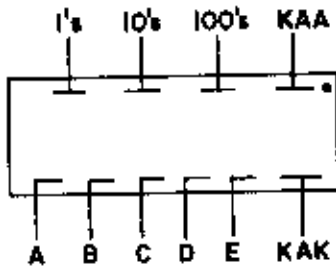

MULTIPLE ELECTRODES: Your game's score displays use 7-segment gas-discharge tubes. These have several cathodes. Each forms one segment of a numeral or letter! The tubes also have many anodes: Each one represents one digit-place on the seven-segment tube. And each selects the letter or digit in that place whenever voltage is applied.

KEEP-ALIVE ELECTRODES. Besides other electrodes, your gas-discharge displays each have one keep-alive anode and cathode! These provide a maintenance voltage in the tube. This means that the striking (illumination) voltage need not be applied whenever segments must glow.

GDD VS. LED: Don't confuse gas-discharge displays with the LED display on the CPU board. That uses a completely different technology:

HALT

HALT-NOT: A low on this MPU input causes the MPU to cease operations and disable its bus buffers. This action permits the busses to be controlled by another device. However the HALT input isn't used in our system (it's permanently tied high):

HEXADECIMAL

COMMONLY ABBREVIATED "HEX." The base-16 numbering system used by programmers to simplify notation of binary numbers: Binary numbers are more easily translated into hex than into the familiar decimal numbering system. Programmers use hex numbers (up to FD95) to describe addresses in eight-bit (64K) computers. These simple hex numbers replace binary numbers up to 16 places long!

INTEGRATED

Numerous transistors per package (as opposed to a discrete circuit, in which each transistor has its own package).

INVERTER

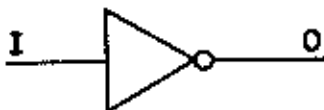

ALSO CALLED INVERTING BUFFER, NOT GATE... A logic gate that outputs a pulse opposite to the one at its input. Besides changing the polarity of logic pulses, inverters are used to increase the fan-out of other chips! Buffers are equivalent to amplifiers in analog electronics: In fact, discrete transistors may be used as buffers (Depending on circuitry, a transistor may or may not invert

a pulse). Your game's 7404 hex inverter chip contains six inverting buffers.

TRUTH TABLE

| I | O |
|---|---|
| H | L |
| L | H |

I/O PORT

INPUT/OUTPUT PORT. Peripherals comprise one of the functional blocks of any computer. A computer's I/O ports couple the microprocessor to the peripherals. Our system has eight I/O ports in the main computer plus two in the sound computer. Each MC6820 or 6821 chip contains two ports (A and B on schematics). Control signals from the MPU determine which ports will be inputs and which will be outputs.

IRQ

INTERRUPT REQUEST-NOT. A normally-pulsing MPU input. With IRQ low, the MPU temporarily sets its main program aside, executes a special subroutine, then returns to the main program.

IRQ A and IRQ B

INTERRUPT REQUEST A and B-NOT. Two PIA outputs (tied together in our system) which stay high until a PIA needs the data bus.

LAMP MATRIX

The game's controlled lamps (up to 64 of them) are wired in series-parallel. Each lamp is in series with an isolation diode. To turn on a controlled lamp, the computer must create two conditions: (1) Feed a ground pulse to the lamp's row; and (2) feed B+ to the lamp's column pin.

K

KILO. Abbreviation for 1,000. When K refers to computer memory capacity, it actually means 1,024. Total memory is usually specified in Kbytes, but chip capacity is usually specified in Kbits.

SIMPLIFIED LAMP MATRIX

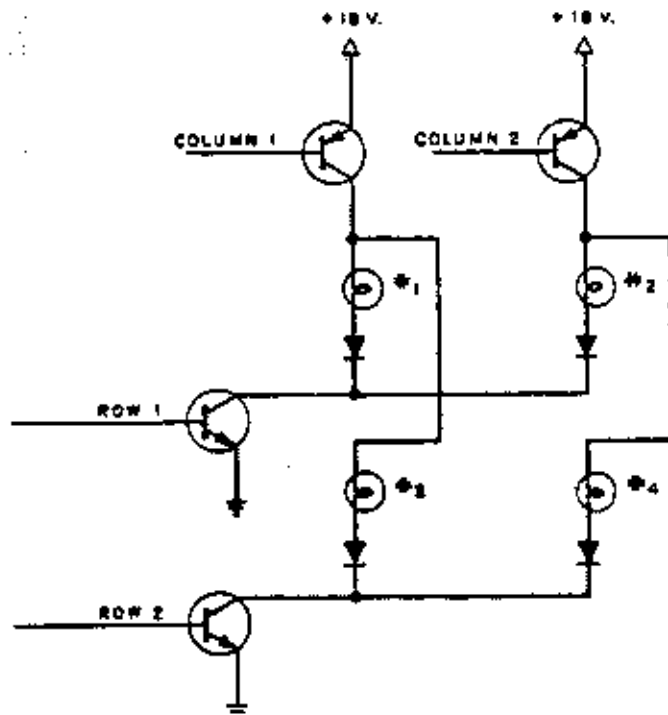

LATCH

A type of flip-flop suited for storing one bit of information.

LEAST-SIGNIFICANT BITS

ABBREVIATED LSB. In a binary number, the digits occupying the rightmost places. Examine the binary number 1110 (equivalent to decimal 14). In this example, the digit "0" is the least-significant bit. Least-significant bits are also referred to as low-order address bits. Your game uses low-order address bits to address RAMs, ROMs, and peripheral devices. On your CPU-board schematics these bits appear as A0 through A11.

LED

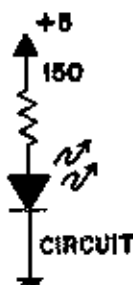

LIGHT-EMITTING DIODE. A semiconductor device that generates light. You'll find LED's in the 7-segment display on your CPU board. Don't confuse these with the gas-discharge tubes in the game's score displays. These use a completely different technology.

LOGIC GATE

Any switching device (including AND, OR, NAND, NOR, XOR, XNOR, YES and NOT circuits and compounds of them). Logic gates produce a high or low output when they receive a high or low input. The output waveform need not conform to the shape, amplitude, phase or frequency of the input waveform (as in analog electronics).

LS

SCHOTTKY CIRCUIT. A type of logic IC that operates with less current than TTL circuits require. LS circuits have a similar numbering scheme to their TTL counterparts (a 74LS prefix instead of a 74 prefix). However TTL and LS aren't always interchangeable. In fact, LS parts have less fan-out than their TTL counterparts. Furthermore, operation speed and propagation delay may be different.

MEMORY PROTECT

The coin door's security signal: It prevents access to the CMOS RAM when the coin door's closed. With the coin door open, MEMORY PROTECT rises high: With the door closed, MEMORY PROTECT drops low. IMPORTANT: When this signal's low, you can't alter your GAME ADJUSTMENTS:

MOS TRANSISTOR

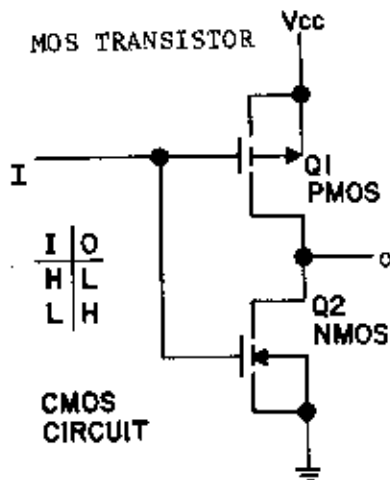

ALSO MOSFET, IGFET: A voltage-controlled switch or valve constructed of silicon or similar crystals.

3 LEGS: MOSFETs usually have three legs including a control leg (the gate) and two power legs (the drain and source): When a MOSFET's turned on, DC flows between the power legs. When a MOSFET's pinched off, there's an open circuit between drain and source.

S-E-X! Like people, MOSFETs are found in two genders. However MOSFET sexes are known as PMOS AND NMOS.

ENHANCEMENT AND DEPLETION. MOSFETs control voltage by permitting carriers (holes or electrons) through a channel that runs between source and drain: In enhancement MOSFETs, this channel doesn't exist until a negative charge

appears at the gate. In depletion MOSFETs, the channel's reduced in proportion to a negative charge at the gate.

MOSFETS IN PINBALL. Your pinball computer has no discrete MOSFETs. However your microprocessor is built with NMOS devices and your CMOS RAM has both NMOS and PMOS devices.

MOST-SIGNIFICANT BITS

ABBREVIATED MSB. In a binary number, the digits occupying the leftmost places. Examine the binary number 1000 (equivalent to decimal 8). In this example, the digit "1" is the most-significant bit. Most-significant bits are also referred to as high-order address bits. Your game uses high-order address bits to select memory chips and PIAs. On your CPU-board schematics these bits appear as A12 through A15. (Although bit 15 isn't used in system 9, system 11 uses it for chip selection.)

For instance, selecting either ROM U19 or U20 involves changing the state of decoder U24. Bits 12 through 14, VMA and E combine to gate U24.

MPU



MICROPROCESSOR UNIT. The MPU is the silicon brain that processes and controls data according to a set of instructions. It's constructed of three units: (1) The arithmetic and logic unit (ALU) that performs computations; (2) the control unit that interfaces with outside memory and peripherals; and (3) internal memory that stores instructions and keeps track of what the MPU must do next. Our system's based on the MC6802 or MC6808 MPU.

MR

MEMORY-READY. This is an active-low MPU input used in some 6802/6808 systems. When tied low, MR stretches E-clock (enable) pulses. The longer pulses allow the MPU to be used with slow memory chips. However the MR control line isn't used in our system (it's permanently tied high).

MULTIPLEXER (MUX)

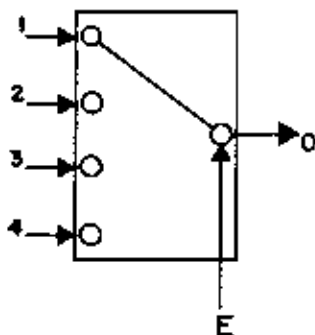

Analogous to a stepper switch. This circuit produces a single output from many inputs.

NAND GATE

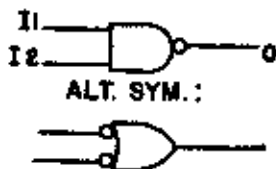

An inverted AND gate, this circuit produces a high (logic 1 or H) output if any input is low. If all inputs are high, the NAND gate produces a low (logic 0 or L) output. Your game's MC14011 chips each contain four NAND gates.

TRUTH TABLE

| I1 | I2 | O |
|----|----|---|
| H | H | L |
| H | L | H |
| L | H | H |
| L | L | H |

NIBBLE

Half a byte, or four consecutive bits:

NMI

NON-MASKABLE INTERRUPT. This active-low MPU input can't be ignored. It tells the microprocessor to enter the Memory-Chip Test.

NOR GATE

An inverted OR gate, this circuit produces a high (logic 1 or H) output only when all inputs are low: All other combinations of input levels produce a low (logic 0 or L) output. Your game's 74LS02 chips each contain four NOR gates. One type of NOR gate permits a low output when one and only one input is high. This type (not used in your game) is called an exclusive NOR (XNOR) gate:

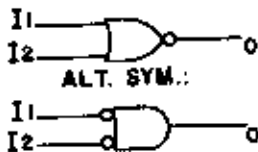

TRUTH TABLE

| I1 | I2 | O |
|----|----|---|
| H | H | L |
| H | L | L |
| L | H | L |
| L | L | H |

OPERATING SYSTEM

The program that manages a computer and its peripherals: If the game program says what to do, the operating system says how to do it.

OR GATE

This circuit produces a high (logic 1 or H) output if any input is high: If all inputs are low, the OR gate produces a low (logic 0 or L) output. Your game's 74LS32 chip contains four OR gates. One type of OR gate permits a high output when one and only one input is high. This type (not used in your game) is called an exclusive OR (XOR) gate.

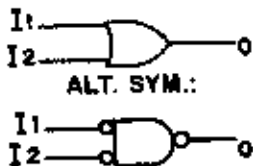

TRUTH TABLE

| I1 | I2 | O |
|----|----|---|
| H | H | H |
| H | L | H |
| L | H | H |
| L | L | L |

OSCILLATOR

A circuit that produces a continuous, periodic waveform: This device is the electronic equivalent of a generator. Actually an oscillator is a non-inverting amplifier whose output signal is fed back to its input.

COMMON OSCILLATORS make square, sine, sawtooth (ramp or sweep), triangle and trapezoid waves. Computer circuits usually include a squarewave oscillator for their system clock: The frequency of this oscillator is often maintained by a piezoelectric (or piezo) crystal.

PA0-PA7 and PB0-PB7

PORT-A AND B PERIPHERAL DATA LINES. These two sets of eight lines represent the two I/O ports of a MC6820 or 6821 PIA. The computer may use each line as an input or output. Usually the port lines should be pulsing.

PARALLEL DATA

Multi-bit information simultaneously transmitted over several lines (usually at least a nibble and up to several bytes at once). Each bit of information requires its own line (or wire) on the bus.

PERIPHERAL

Input/output equipment of a computer. Your pinball computer incorporates many examples such as...

- *lamps
- *solenoids
- *displays
- *drop targets
- *the bell
- *the sound/speech computer
- *the general-illumination relay
- *playfield switches

PIA

PERIPHERAL-INTERFACE ADAPTER. Our system uses the MC6820 or MC6821 PIA chips. These chips permit the MPU to communicate with devices outside the computer's bus system. Each PIA has two I/O ports for the MPU's use. External devices are connected to one side of a port and the computer's bus system is connected to the other side.

PIEZO CRYSTAL

PICTORIAL

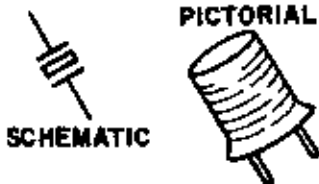

SCHEMATIC

This slice of quartz vibrates at its natural frequency when whenever voltage is applied. Crystals are used instead of coils and capacitors in tuned circuits and oscillators.

PROPAGATION DELAY

ALSO KNOWN AS ACCESS TIME. Each time a signal passes through a logic gate, the output slightly lags the input. This lag in output is primarily due to the internal capacitance of transistors, MOSFETs and other gates. If a signal (function) passes through several gates, it may emerge in the wrong phase: That is, it may be inverted (at the opposite logic level from the desired signal).

RAM

RANDOM-ACCESS MEMORY. RAMs are read-write memories. The MPU can use them for temporary storage during its computations. In fact the MPU uses RAM the way a technician might use a scratchpad.

RD

When the MPU decides to read data from a particular memory or port location, the MPU pulls this output low. This control line isn't used in our system (it's permanently tied low).

RE

RAM ENABLE. This signal controls the on-chip RAM of the MC6802/6808. When placed in the high state, the on-chip memory is enabled. RE is tied low (disabled) in our system.

- ROM READ-ONLY MEMORY. This is a permanent memory. There are several types of ROM. The most common is the EPROM. For information on the ROMs used in your machine, consult the ROM SUMMARY in your game's manual.
- R/ \bar{W} READ/WRITE-NOT. An MPU output. When this function's high, the MPU reads the data bus. When this function's low, the MPU writes on the data bus.
- $\overline{\text{RESET}}$ RESET-NOT. When this MPU input's low, the MPU isn't running. RESET-NOT is used to initialize the system or restart it. At least 4.0 VDC must be at the MPU's reset pin before the system will run.
- SCR SILICON CONTROLLED RECTIFIER. A three-terminal electronic device designed to switch DC. Unlike a transistor, an SCR can't be operated as a valve (that is, SCRs aren't linear devices). Instead, SCRs are basically diodes with a third leg called the gate. Current through the gate turns the SCR on. At this point the gate loses control of the device. An SCR only switches off when its anode-to-cathode voltage falls to zero. Your game uses 2N5060 SCRs in its lamp row (return) circuitry.
- SERIAL DATA Multi-bit information sequentially transmitted over a single line.
- SIP SINGLE-INLINE PACKAGE. This term defines the comblike shape of some integrated circuits. Such devices are rectangular, with legs descending in a single row. SIP capacitors and SIP resistors are also common.
- $\overline{\text{ST1}} - \overline{\text{ST6}}$ SOLENOID TRIGGER ONE THROUGH SIX-NOT. These are signals from different PIA's. These six should usually be high.
- STATIC RAM ALSO SRAM. This type of random-access memory doesn't need to be refreshed. That is, SRAMs store information until changes are entered by the computer or until their power's removed. Your game's 5517AP CMOS RAM is the static kind. So is the 6810 RAM in the sound computer.
- SWITCH MATRIX The switch matrix in your game permits scoring data to be retrieved by the microprocessor. The game's scoring

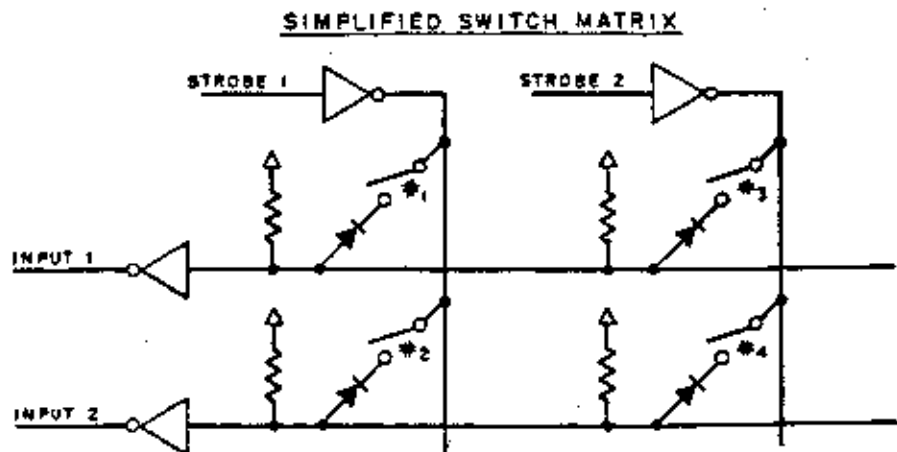

switches (up to 64 of them) are wired in series-parallel. Each switch is in series with an isolation diode. Closing a switch connects a row line to a column line.

THE SWITCH PIA. Actually, switch closure completes a circuit that begins and ends with the switch PIA. The switch PIA pulses each column of the matrix in turn. The same PIA scans each row in turn for an output. However an output only results if a switch closes.

TIMER

Timer chips are a form of piezoelectric oscillator. Your pinball computer uses an MC1455 timer chip for its system clock:

TRANSCEIVER

Both transmitter and receiver in the same IC. Circuitry is shared by the transmitter and receiver. Your game uses a 74LS245 octal bus transceiver.

TRANSISTOR
BUFFERS

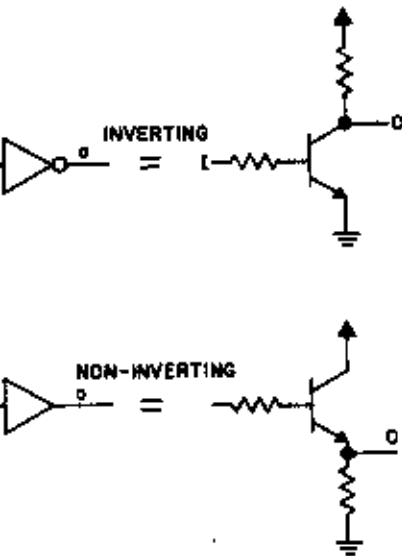

SWITCH, VALVE, GATE...An electronic switch or valve constructed of silicon or similar crystals. Transistors are sometimes considered equivalent to buffers. As such a single transistor is also the simplest logic gate. Other logic gates consist of two or more transistors. Instead of two gates, your game uses a discrete transistor to enable the CMOS RAM:

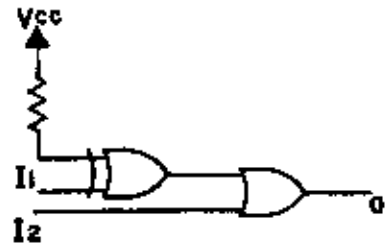
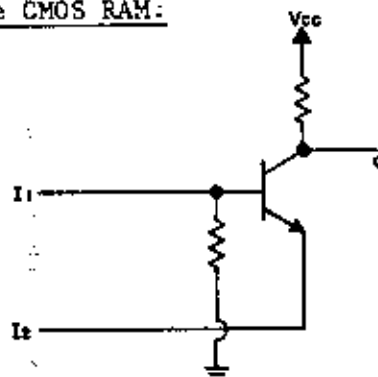

The CMOS-RAM enabling transistor and its equivalent using XOR and OR gates.

| | TRUTH TABLE | | |
|---|-------------|----|---|
| RESET=input I1 | I1 | I2 | Q |
| | H | H | H |
| CE.CMOS=input I2 | H | L | L |
| | L | H | H |
| CE input to CMOS RAM U18, pin 18=output Q | L | L | H |

BIPOLAR. The transistors you'll find in pinball games are mostly the type known as bipolar. Remaining comments refer to bipolar transistors.

3 LEGS. Transistors have three legs including a control leg (the base) and two power legs (the collector and emitter). When a transistor is turned on (saturated), DC flows between the power legs. When a transistor's cut off, there's an open circuit between collector and emitter.

TEST TRANSISTORS WITH THESE CIRCUITS

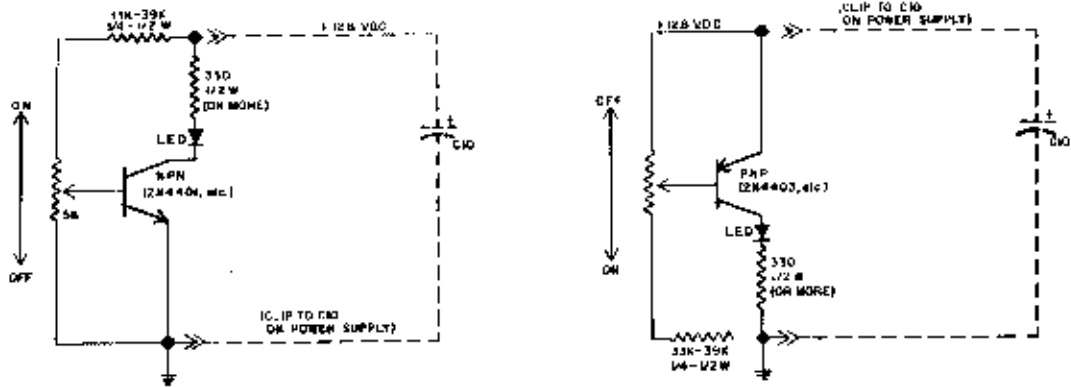

TURNING ON...Bring a transistor's base voltage near the emitter voltage: The transistor turns off. Now turn the transistor on: Just raise the base 0.7V away from the emitter (toward the collector). As soon as threshold current flows between emitter and base, a much larger current will flow between the emitter and collector. In short, the transistor has turned on.

S-E-X! Like people, transistors are found in two genders. However transistor sexes are known as PNP and NPN.

TRISTATE

This term refers to chips that have a third state besides high (+5V) and low (0V). In this third state the chip presents a high impedance to the bus. This means that the bus isn't loaded by chips at rest. More tristate chips than two-state chips can use the same bus.

TRUTH TABLE

A chart of what logic values a gate outputs according to all possible input values.

TTL

TRANSISTOR-TRANSISTOR LOGIC. The most common family of digital chips: Circuits based on this system incorporate bipolar transistors operating at 5VDC: TTL chips usually have a prefix of 74 (54 for mil-spec parts) in their part numbers.

TTL VS. LS VS. CMOS...

- * TTL parts operate faster than CMOS parts.
- * TTL parts have a greater fan-out than LS (part numbers such as 74LS...) parts.
- * LS parts are usually faster than TTL parts.
- * CMOS parts require less power than TTL parts.
- * Because of these differences, never casually intermix logic families!

Vcc

A transistor's collector-voltage supply: Also, the main power supply for a semiconductor circuit.

VMA

VALID MEMORY ADDRESS: This MPU output goes high every time addresses are stable (high or low). VMA is low whenever addresses are in transition: Carefully monitoring VMA status, the MPU only initiates bus operation when the bus is stable:

- X Abbreviation for the prefix trans-. Also used in XTAL to shorten the word crystal.
- XTAL CRYSTAL CLOCK. In systems where a discrete crystal is used for the main clock, the MPU's XTAL and EXTAL pins are both attached to the crystal. Since our system uses an external clock at the EXTAL pin, the XTAL pin is tied to ground (disabled).

ZENER DIODE



A two-terminal crystal that maintains an open circuit until a certain voltage (the zener voltage) is attained. At this point the zener diode conducts current. Zeners are always used in the reverse-biased mode (that is, with their anodes attached to ground).

Amplified zeners as voltage regulators

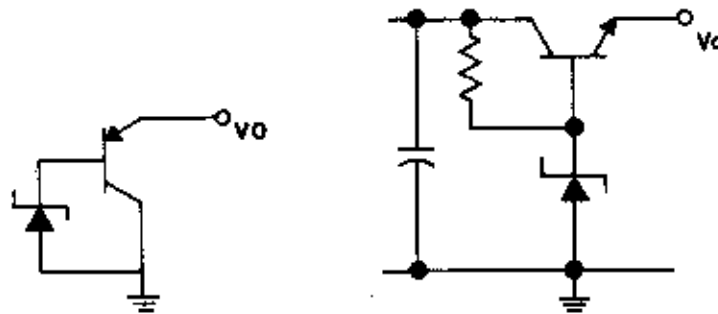

Pin Functions of 6802 and 6808 Microprocessors

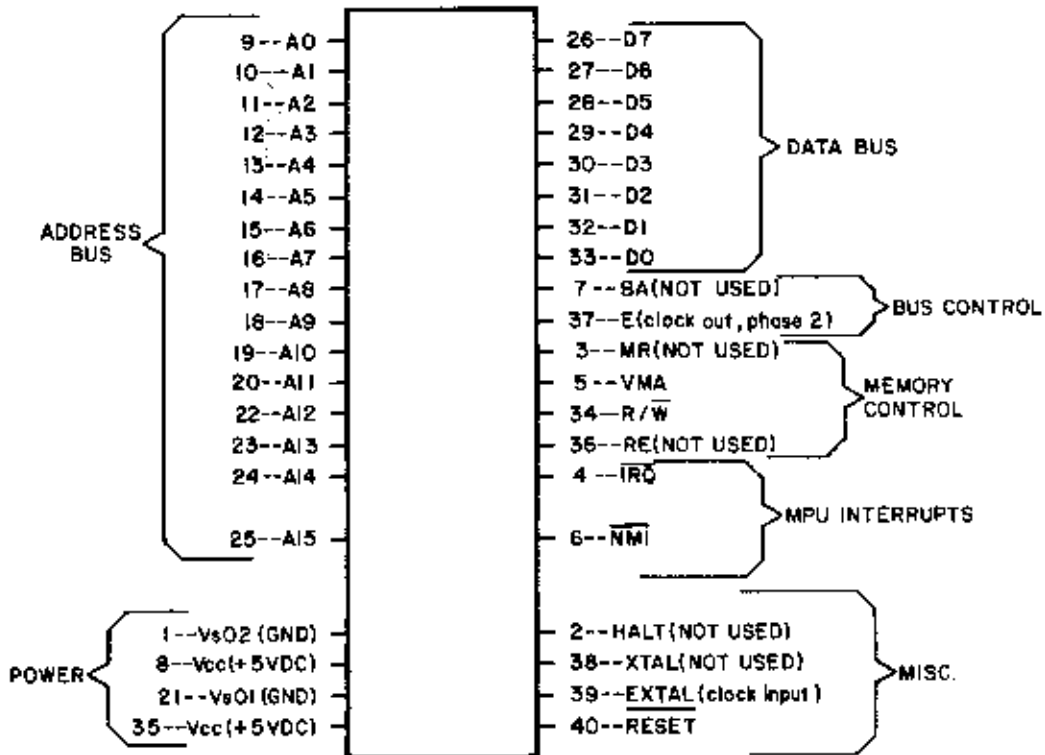

System-9 Control Locations

THE ON-OFF SWITCH is on the bottom of the cabinet near the right-front leg, as you face the game.

THE VOLUME CONTROL is accessible through the coin door on the left cabinet-wall.

DIAGNOSTIC/GAME-SETTING SWITCHES. ADVANCE, AUTO-UP/MANUAL-DOWN, and HIGH-SCORE RESET switches are located on the inside of the coin door. For operation, refer to your game's manual.

THE MEMORY-PROTECT SWITCH is on the inside of the coin-door frame. This switch must be open to clear bookkeeping totals and to make game adjustments. It automatically opens when the coin door opens.

ALL CIRCUIT BOARDS are in the backbox.

THE CPU-DIAGNOSTIC SWITCH is on one edge of the CPU Board near a microprocessor (large, socketed) chip. This switch operates the Memory-Chip Test explained in your game's manual.

THE SOUND DIAGNOSTIC-SWITCH is on the CPU Board near the batteries. This switch is used to initiate the Sound-Section Test. Refer to your game's manual.

THE SOUND-SPEECH MIXER POT is only found in talking games; it is on the Speech Board. This pot permits the operator to balance sound and speech to suit the game location.

Replacing System-9 Circuitboards

CPU BOARD. Your System-9 CPU Board (D-10535) must be equipped with the ROMs specified in the ROM Summary. Only jumpers specified in your game's manual should be connected.

DISPLAY BOARDS. Use the D-10749 Master Display Board with C-8364 7-digit Slave Displays. One C-8365 4-digit Slave Display is also necessary.

POWER-SUPPLY BOARD. Use the D-8345 board (equipped with a relay).

All About Coil Numbers

NEW SYSTEM. WILLIAMS has a new numbering system for 23-gauge, 800-turn coils. The part number's two-letter prefix identifies lug positions as viewed from the coil's round end, with the lugs pointing away from you: AR- means that the coil's two lugs are mounted in the two end positions. AL- means that the coil's lugs are mounted in the left and middle positions. AR- means that the coil's lugs are mounted in the middle and right positions.

The next two numbers (23) identify the gauge of magnet wire used in the coil. The number of turns is specified next (800). The diode and tubing used in the coil are called out in the final number (-01, -02,...). A list of old coil part numbers and their new equivalents follows.

| OLD COIL NUMBER | NEW EQUIVALENT |
|-----------------|----------------|
| SA-23-850-DC | AE-23-800-01 |
| SA7-23-850-DC | AE-23-800-02 |
| SG1-23-850-DC | AE-23-800-03 |
| SA3-23-850-DC | AE-23-800-04 |
| SA2-23-850-DC | AE-23-800-05 |
| SG-23-850-DC | AE-23-800-06 |
| SA4-23-850-DC | AE-23-800-07 |
| SAL-23-850-DC | AL-23-800-01 |

An Introduction to Self-Diagnostics

TECHNICAL SOFTWARE. Your game has an amazing capacity for entertainment. Yet part of your game's potential is never seen by players. Deep in the System-9 background program is a set of routines strictly for service technicians. With these routines, your game can actually help service itself.

SIMPLE AND FAST...Leave your test gear in the truck and spend ten minutes with the machine! Just two buttons in the backbox test all nine memory chips, the microprocessor and the clock circuit. With two buttons on the back of the coin door plus the CREDIT button on the cabinet, you can check the game's lamps, sounds, solenoids...and more! Here are three of many tests you can perform using the game itself as your test device. Consult your game's instruction manual for information on other tests.

PRESS THE CPU-BOARD DIAGNOSTIC SWITCH. This switch is on one edge of the CPU Board near a microprocessor (large, socketed) chip. The game enters its Diagnostic Mode and performs the Memory-Chip Test. Memories checked include Game-ROMs 1 and 2. The game's clock and the microprocessor are also checked. Test results appear as a numeric code on the CPU board's LED display. Assuming the tests are passed, a "0" should be visible and Game-Over Mode will commence. Other indications require procedures covered in this book's electronic-troubleshooting section.

MEMORIES TESTED SEPARATELY...The sound ROM, sound RAM and speech ROMs (part of a separate computer on the same board) aren't tested in the Memory-Chip Test. Use the SOUND-DIAGNOSTIC switch to test the sound/speech computer. Consult your game's instruction manual for complete details.

AUTO-CYCLE MODE permits continuous tests for intermittent problems with the displays, sounds, lamps and solenoids (respectively). Problem areas can be inspected by using more-specific built-in tests. Consult your manual for information on these. Meanwhile, here's the procedure for entering Auto-Cycle Mode...

1. Enter Bookkeeping Mode: Set the AUTO-UP/MANUAL-DOWN switch to AUTO-UP.
2. Now hold down ADVANCE until "04 50" appears in the CREDITS/MATCH display.
3. Use CREDIT to enter a 15 in the PLAYER-1 display.
4. Now press ADVANCE.

Auto-Cycle Mode repeats its four tests until you turn the game off and back on.

System-9 Games Play on System 11

Although System 9 is out of production, WILLIAMS assures downward compatibility with System 11. In fact all system-9 games will play on the system-11 computer. Conversion is simple and fast. Jumpers and ROMs are changed, and then you install the new system in your backbox. (A new speech ROM is necessary.) For details, consult the CPU-Board Jumper Table and the Speech-ROM Comparison Table.

CPU-Board Jumper Table

| JUMPER | FUNCTION | GAME NAME..... | | |
|--------|--|----------------|-----------------------------------|----------------------|
| | | HIGH SPEED | ALLEY CATS, SORCERER, STRIKE ZONE | COMET, SPACE SHUTTLE |
| W1 | oscillator to system | in | in | in |
| W2 | memory configuration | in | out | in |
| W3 | " " | out | in | out |
| W4 | " " | in | out | out |
| W5 | +5VDC to pullup resistor on opto input | in | in | in |
| W6 | +12VDC to pullup resistor on opto input | out | out | out |
| W7 | jumper for German settings (USA games:) | in | in | in |
| W8 | sound proc RESET from proc-control RESET | in | out | out |
| W9 | sound processor RESET from system RESET | out | in | in |
| W10 | +18VDC to sound amplifier | out | out | out |
| W11 | +12VDC to sound amplifier | in | in | in |
| W12 | address-buffer enable | in | in | in |
| W13 | data-buffer enable | in | in | in |
| W14 | 1 mS IRQ signal | in | in | in |
| W15 | 2 mS IRQ signal | out | out | out |
| W16 | BLANKING to input 'D' of LED decoder | in | out | out |

Speech-ROM Comparison Table

| SYSTEM | ROM NO. | CHIP TYPE | DESCRIPTION | CHIP NO. | BOARD | ADDRESSES (IN HEX) |
|--------|---------|--------------|-------------|----------|--------|--------------------|
| 11 | 2 | 27128 | 16Kx8 BITS | U22 | CPU | 8000-BFFF |
| 9 | 1 | 2532 or 2732 | 4Kx8 BITS | U7 | SPEECH | 8000-8FFF |
| 9 | 2 | 2532 or 2732 | 4Kx8 BITS | U8 | SPEECH | 9000-9FFF |
| 9 | 3 | 2532 or 2732 | 4Kx8 BITS | U9 | SPEECH | A000-AFFF |
| 9 | 4 | 2532 or 2732 | 4Kx8 BITS | U108 | SPEECH | B000-BFFF |

System 9 to System 11 Conversion Table For Chapter 3

This table helps you service System-11 games. Most System-11 circuits are equivalent to System-9 circuits. However part callouts differ between games. The table provides System-11 equivalents for System-9 parts referred to in Chapter 3. A special section compares callouts for the System-9 and System-11 sound sections with callouts for the System-11 background sound board. Equivalents for illustration callouts are not presented. Please consult your game's schematics.

| PAGE | SYSTEM-9 PART | SYSTEM-11 PART | CIRCUIT | PART DESCRIPTION |
|------|--|--|---|--|
| 28 | U15 U18 D3 U43 U16 U34 U41 | U17 U25 D2 U4 See note See note See note | MPU Backup memory Backup memory Backup memory Backup memory Backup memory Backup memory | Main microprocessor CMOS RAM Diode NAND gate OR gate AND gate Inverter |
| 30 | Q52 Q7-Q14 C10 C1 | Q40 Q42-49 C10 C1 | Backup memory Switch columns Main power supply Flipper power supply | Transistor Transistors Capacitor Capacitor |
| 31 | 15P4 | 15P1 | Flipper power supply | input connector |
| | | REST OF PART CALLOUTS ON P. 31 ARE SAME! | | |
| 32 | 1J19 K1 U51 U52 | 1J19 K1 U30 U39 | CPU output Solenoid Switch row Switch row | Solenoid connector Ground relay Input NAND gate Input NAND gate |
| 34 | U51 U52 SR8 Q7-Q14 | U30 U39 SR15 Q42-49 | Switch row Switch row Switch column Switch column | Input NAND gate Input NAND gate SIP resistors Transistors |
| 35 | U22 U59 U6 U58 | U43 U55 U50 U56 | Reset Blanking Blanking Blanking | 555 clock Inverter NOR gate Inverter |
| 38 | U56 U57 U60 U61 | U17 U18 U19 U20 | Solenoid Solenoid Solenoid Solenoid | AND gate AND gate AND gate AND gate |
| 39 | 1J18 | 1J18 | CPU output | Connector |
| 40 | SR4 Q23-30 Q31-38 | SR16 Q52-66 even Q80-87 | Lamp column Lamp column Lamp row | SIP resistors Driver transistors Driver transistors |

CAUTION: Different circuitry is used. No direct equivalent.

| PAGE | SYSTEM-9 PART | SYSTEM-11 PART | CIRCUIT | PART DESCRIPTION |
|--|--|--|---|--|
| 41 | LJ5 K1 3J9 3J8 | LJ5 K1 3J9 3J8 | Lamp row General illumination General illumination General illumination | Ground connector Relay Input connector Output connector |
| 42 | 3J8 8J8 7P1 9P1 K1 Q56 IC13 IC1 | 3J8 8J8 7P6 9P2 K1 Q16 U1 & U5 U13 & U14 | General illumination General illumination General illumination General illumination General illumination Solenoid Master display Master display | Output connector Playfield connector Cabinet connector Backbox door (insrt) Relay Driver transistor Digit-anode driver Segment-cathode dr |
| 44 | IC1 IC2 1J3 4J7 1J1 1J2 SR11 SR12 U9 4J5 IC9-11 IC7,8,12,13 | U13 & U14 U9 & U12 1J3 4J1, 4J12* 1J1 1J2 SRC7 SRC8 U44 4J2, 4J3* U3, 4, 7, 8* U5, 1, 6, 2* | Master display Master display CPU BCD disp output Master display CPU display strobe CPU display strobe CPU display strobe CPU display strobe CPU display strobe Master display Master display Master display | Segment-cathode dr Segment-cathode dr Output connector Input connector Output connector Output connector SIP resistor pack SIP resistor pack Decoder Input connector Strobe inverters Digit-anode drivers |
| 45 | IC9-11 | U3, 4, 7, 8* | Master display | Strobe inverters |
| REST OF PART CALLOUTS ON P. 45 ARE SAME! | | | | |
| 47 | 3J5 Q1 Q2 | 3J5 Q1 Q2 | Main power supply Main power supply Main power supply | Display connector Transistor Transistor |

***CAUTION:**

Circuitry is similar but not identical. Pinouts differ and chips are not interchangeable. Examine schematics for your game before you service it.

| PAGE | SYSTEM-9 PART | SYSTEM-11 CPU PART | SYSTEM-11 BG SOUND BOARD | CIRCUIT | PART DESCRIPTION |
|------|---|---|---|---|--|
| 47 | SW2 U13p2-9 C7 U59 C29 | SW1 U9p2-9 C26 U1 C5 | None U2p10-17 C26 None None | Sound Sound Sound Sound Sound | Diagnostic button PIA pins Capacitor Power amplifier Capacitor |
| 48 | C24 U11 U12 U49 U17 U13 C31 Q51 U48 | C2 U24 U23* U21, U22* U15 U9 C7 Q1 U2 | None U5* U3* U4* None U2 C2 Q1 U1 | Sound Sound Sound Sound CPU Sound Sound Sound Sound | Capacitor Sound MPU Sound RAM Sound ROM Main MPU PIA Capacitor Transistor DAC chip |
| PAGE | SYSTEM-9 PART | SYSTEM-11 PART | CIRCUIT | | PART DESCRIPTION |
| 48 | U20 U19 1J17 U17 F5 F6 | U27* U26 1J17 U15 F5 F6 | CPU CPU CPU CPU Power supply Power supply | | Game-ROM 1 Game-ROM 2 Power connector Main MPU Fuse Fuse |
| 49 | TP3 TP1 IC1 U17 C10 | TP3 TP1 IC1 U15 C10 | Power supply Power supply Power supply CPU Power supply | | Test point Test point Regulator IC Main MPU Capacitor |
| 50 | U17 U21 U20 U11 U19 U24 | U15 CR1 U27* U24 U26 U37, U12* | CPU CPU CPU Sound CPU CPU | | Main MPU Clock crystal Game ROM 1 Sound MPU Game-ROM 2 Address decoder |
| 51 | U17 R8 U2 U3 C12 | U15 DS1 U5 U4 C15 | CPU 9: Speech; 11: CPU Speech Speech Speech | | Main MPU Sound/speech mixer Filter/preamp IC Filter/preamp IC Capacitor |
| 52 | U2 U4-U7 U49 | U5 U21, U22* U21, U22* | Speech Speech Sound | | Filter/preamp IC Speech ROMs Sound ROM |

***CAUTION:**

Circuitry is similar but not identical. Pinouts differ and chips are not interchangeable. Examine schematics for your game before you service it.

Index
to the First Three Chapters

A-B-C-D

| | |
|--|--------------------|
| Address Bus..... | 21 |
| Adjusting switches..... | 13 |
| Architecture, System..... | 20 |
| Backbox glass, cleaning..... | 8 |
| Backup blades..... | 8, 13 |
| Ball-roll tilt..... | 9 |
| Ball trough, lubricating..... | 13 |
| Blanking circuit: Pulls in all coils when I turn game on..... | 24 |
| <u>Bookkeeping Mode</u> , game stuck in..... | 28 |
| Bookkeeping Table..... | 16 |
| Brackets, mounting (flippers, drop targets)..... | 11 |
| Bushings..... | 11 |
| Bus problems..... | 48 |
| Capacitors on power supply..... | 10, 30, 31, 49, 50 |
| Checkup, Five-Minute..... | 9 |
| Circuitboards, Replacing System-9..... | 69 |
| Clock problems..... | 48 |
| Coil problems..... | 35 |
| Coils, flipper..... | 12 |
| Coil numbers..... | 69 |
| Coil sleeves..... | 11, 12 |
| Coil stops..... | 11 |
| Coils: When I turn it on, game pulls in all coils..... | 35 |
| Coin-chute test..... | 9 |
| Connectors, burned..... | 10 |
| Connector Code..... | 2 |
| Control bus..... | 21 |
| Control Locations, System-9..... | 69 |
| CPU-Board Jumper Table..... | 71 |
| Crank arm..... | 12, 13 |
| Crashes or refuses to enter <u>Game-Over Mode</u> | 30 |
| Data Bus..... | 21 |
| Diagnosing Common Symptoms..... | 28 |
| Diagnostics, Self-..... | 9, 70 |
| Digits and Volts..... | 25 |
| Display Problems..... | 42 |
| Displays always blank..... | 45 |
| Displays: missing segments or digits on one slave display..... | 44 |
| Displays: missing segments on two displays..... | 44 |

Displays "strobe"..... 45
Drop targets..... 8, 10
Dynamic refreshment..... 26

E-F-G-H-I-J-K-L

Electronic Test Equipment..... 28
Eject assembly, lubricating..... 13
Eject hole, lubricating..... 13

Electronic and Electromechanical Troubleshooting..... 19
EOS actuator, insulation on..... 12
EOS switch..... 11, 12, 31

Fiber link..... 12
Flipper assembly (mechanical aspects)..... 11, 12
Flippers (electromechanical and electronic aspects)..... 30

Flipper coils burn up..... 35
Flipper crank-arm assembly, lubricating..... 13
Flippers dead..... 31

Flippers: one is weak..... 31
Flipper problems..... 31
Flippers, weak..... 30

Flipper-wear points..... 11
Flipper wiring..... 11
Function Finder: A glossary of electronic terms..... 54

Fuse F1 always blows (1/4A)..... 45
Game-Adjustment Table..... 8, 16
Game-Over Mode, Won't enter..... 48, 50

Game-Registration Card..... 16
Interrupt..... 25
Ground Source for Testing..... 28

Jet bumpers (mechanical aspects)..... 11, 13, 14
Jumpers, CPU board..... 71
Kicker coils burn up..... 35

Kickers, lubricating..... 13
Lamp-column failure..... 41
Lamp-Matrix Table..... 16

Lamp problems..... 39
Lamps: controlled lamps don't work..... 40
Lamps: flashlamps don't work..... 39

Lamps: general-illumination lamps don't work..... 41
Lamps: lamp-row failure..... 41
Lamps: no general illumination and no controlled lamps..... 42

| | |
|---|--------|
| LANE-CHANGE™ switch..... | 32 |
| Leaf switches (servicing)..... | 10, 13 |
| Light bulbs..... | 10 |
| Linear Power Supplies..... | 30 |
| Locked-up game..... | 48, 50 |
| Lubrication points..... | 13 |
| Lubricating the kicker assembly..... | 13 |
| Lubricating the ball trough..... | 13 |
| Lubricating the eject assembly..... | 13 |
| Lubricating the flipper crank-arm assembly..... | 13 |
| Lubricating jet bumpers..... | 13 |

M-N-O-P-Q-R

| | |
|--|--------|
| Jet bumper, lubricating..... | 13 |
| Maintenance Procedures, Electronic..... | 27 |
| Major Service Procedures (mechanical)..... | 11 |
| Mechanical Adjustments (flippers and eject holes)..... | 12 |
| Mechanical-difficulty adjustments..... | 8 |
| Mechanical Servicing..... | 7 |
| Microprocessor: Devices beyond microprocessor control..... | 26 |
| Microprocessors, Pinouts for 6802 and 6808..... | 22, 68 |
| Microswitches (servicing)..... | 13 |
| Mounting brackets (flippers, drop targets)..... | 10, 11 |
| Mylar, playfield..... | 8 |
| Object code..... | 25 |
| I stuck on CPU-board indicator..... | 48, 50 |
| Periodic, Major Service Procedures (mechanical)..... | 11 |
| Pinouts for 6802 and 6808 Microprocessors..... | 22, 68 |
| Pivot points, spinning-target..... | 13 |
| Plastics..... | 11 |
| Playfield, cleaning the..... | 8 |
| Playfield pitch and the plumb-bob ring..... | 9 |
| Playfield, waxing the..... | 8 |
| Playfield posts..... | 8 |
| Playfield pitch..... | 8 |
| Plumb-bob adjustments..... | 10 |
| Plunger, ball-shooter..... | 10 |
| Power problems..... | 48 |
| Power supplies..... | 30 |
| Procedures, Periodic Service (mechanical)..... | 11 |
| Publications, Using The..... | 15 |
| +118V on the +100V line..... | 47 |
| Preface..... | 5 |

Reading data..... 26
Real Time..... 25
Reference Information..... 53

Reset circuit.....48, 49
Return spring..... 11
ROM Summary for a Typical System-9 Game..... 2

Rubber rings--replacing.....10, 11

S-T-U-V-W-X-Y-Z

Screws, mounting.....10, 11
Service Procedures (electronic)..... 27
Service Procedures, Periodic, Major (mechanical)..... 11

Service Program, Weekly 10
Setup Procedures..... 8
7 stuck on CPU-board indicator.....28, 48, 50

Slam-tilt switch adjustments..... 9
Solenoid broken..... 38
Solenoid Table..... 18

Sound, never has any..... 47
Sound: None in DIAGNOSTIC TEST (but sounds are present in Self Test)..... 47
Sounds present, but not speech..... 47

Sound problems..... 47
Source code..... 25
Speech-board problems..... 51

Speech-ROMs, comparison between system 9 and system 11..... 71
Spinning-target pivot points..... 13
Stalled game.....48, 50

Switch adjustment.....13, 14
Switch-column problems..... 34
Switches: Game has row problems..... 34

Switches: One causes three others to actuate..... 34
Switches open, but game awards points..... 34
Switch-Matrix Table..... 18
Switch problems..... 32

Switch problems: always has rows 1-4 or 5-8 on..... 32
System Architecture..... 20
System 11.....6, 19, 25, 71, 72

Systems 4, 6, 7 and 8.....5, 6
System 9.....2, 5, 6, 69, 71, 72
System 9 and the 6802/6808 Microprocessor..... 25

| | |
|---|--------|
| System-9 Games (in chronological order)..... | 6 |
| System-9 Games Play on System 11..... | 71 |
| System 9 To System 11 Conversion Table For Chapter 3..... | 72 |
| Tilt-mechanism adjustments..... | 9 |
| Tilt mechanism: ball-roll tilt..... | 9 |
| Tilt mechanism: playfield pitch and the plumb-bob ring..... | 9 |
| Tilt mechanism: slam-tilt switch adjustments..... | 9 |
| Tilts or gives free credits..... | 30 |
| Wear points, flipper..... | 12 |
| Weekly Service Program..... | 10 |
| Words missing..... | 52 |
| Writing data..... | 26 |
| 0 stuck on CPU-board indicator..... | 48, 50 |

